



SECTION A. Table of Contents

Section A. Facility/Source Identification

Table of Contents
Site Inventory List

Section B. General State Only Requirements

- #001 Definitions.
- #002 Operating Permit Duration.
- #003 Permit Renewal.
- #004 Operating Permit Fees under Subchapter F.
- #005 Transfer of Operating Permits.
- #006 Inspection and Entry.
- #007 Compliance Requirements.
- #008 Need to Halt or Reduce Activity Not a Defense.
- #009 Duty to Provide Information.
- #010 Revising an Operating Permit for Cause.
- #011 Operating Permit Modifications
- #012 Severability Clause.
- #013 De Minimis Emission Increases.
- #014 Operational Flexibility.
- #015 Reactivation of Sources
- #016 Health Risk-based Emission Standards and Operating Practice Requirements.
- #017 Circumvention.
- #018 Reporting Requirements.
- #019 Sampling, Testing and Monitoring Procedures.
- #020 Recordkeeping.
- #021 Property Rights.
- #022 Alternative Operating Scenarios.
- #023 Prohibition of Air Pollution
- #024 Reporting
- #025 Report Format

Section C. Site Level State Only Requirements

- C-I: Restrictions
- C-II: Testing Requirements
- C-III: Monitoring Requirements
- C-IV: Recordkeeping Requirements
- C-V: Reporting Requirements
- C-VI: Work Practice Standards
- C-VII: Additional Requirements
- C-VIII: Compliance Certification
- C-IX: Compliance Schedule

Section D. Source Level State Only Requirements

- D-I: Restrictions
- D-II: Testing Requirements
- D-III: Monitoring Requirements
- D-IV: Recordkeeping Requirements
- D-V: Reporting Requirements
- D-VI: Work Practice Standards
- D-VII: Additional Requirements

Note: These same sub-sections are repeated for each source!

Section E. Source Group Restrictions



SECTION A. Table of Contents

- E-I: Restrictions
- E-II: Testing Requirements
- E-III: Monitoring Requirements
- E-IV: Recordkeeping Requirements
- E-V: Reporting Requirements
- E-VI: Work Practice Standards
- E-VII: Additional Requirements

Section F. Alternative Operating Scenario(s)

- F-I: Restrictions
- F-II: Testing Requirements
- F-III: Monitoring Requirements
- F-IV: Recordkeeping Requirements
- F-V: Reporting Requirements
- F-VI: Work Practice Standards
- F-VII: Additional Requirements

Section G. Emission Restriction Summary

Section H. Miscellaneous

**SECTION A. Site Inventory List**

Source ID	Source Name	Capacity/Throughput	Fuel/Material
032	DUAL FUEL BOILERS (NG AND NO. 2)	N/A	Natural Gas
		N/A	#2 Oil
033	NO. 2 FUEL OIL BOILERS	N/A	#2 Oil
100	DRY BUILDING 1 - PLASTIC MASTERBATCH CENTER	N/A	
126	TWO (2) EMERGENCY GENERATORS	N/A	#2 Oil
200	WET BUILDING 2 - LIQUID DISPERSION CENTER	N/A	
204	MAINTENANCE AREA REMOTE RESERVOIR PARTS WASHER		
214	BUILDING 2 PARTS WASHERS		
C01	DUST COLLECTOR, WET BUILDING, LARGE PRE-OXY	N/A	
C03	REGENERATIVE THERMAL OXIDIZER	N/A	
C04	DUST COLLECTOR, DRY BUILDING A/B	N/A	
C102	DUST COLLECTOR WET C1	N/A	
C105	DUST COLLECTOR WET D1	N/A	
C110	DUST COLLECTOR, 12000 CFM, DRY C/D LINE, FOR 110	N/A	
C111	DUST COLLECTOR 7,500 CFM, DRY C1, C2 FOR 111	N/A	
C112A	DUST COLLECTOR, 10,000 CFM, DRY C LINE C1 C2 AND C3	N/A	
C112B	DUST COLLECTOR 1,800 CFM, DRY C3	N/A	
C113	DUST COLLECTOR 2,150 CFM, DRY C5, FOR 113	N/A	
C114	DUST COLLECTOR 5,000 CFM, DRY PM ROOM, FOR 114	N/A	
C118A	DUST COLLECTOR, 3,500 CFM, DRY CONTINUOUS LINE C4	N/A	
C205	DUST COLLECTOR, DRY BUILDING HENSCHEL	N/A	
C209	DUST COLLECTOR, WET BUILDING, D-WING #1	N/A	
C211	DUST COLLECTOR, WET BUILDING, D-WING #2	N/A	
C213	DUST COLLECTOR R 12,000 CFM DRY BUILDING	N/A	
FML01	NATURAL GAS		
FML02	NO. 2 FUEL OIL		
S110	STACK		
S111	STACK		
S112A	STACK		
S112B	STACK		
S113	STACK		
S114	STACK		
S118A	STACK		
S201	DRY BUILDING A/B DUST COLLECTOR STACK		
S203	OXIDIZER STACK		
S205	DRY BUILDING HENSCHEL DUST COLLECTOR STACK		
S213	STACK 213		

**SECTION A. Site Inventory List**

Source ID	Source Name	Capacity/Throughput	Fuel/Material
Z031	MISCELLANEOUS COMBUSTION STACK		
Z100	ENGINE EXHAUST		

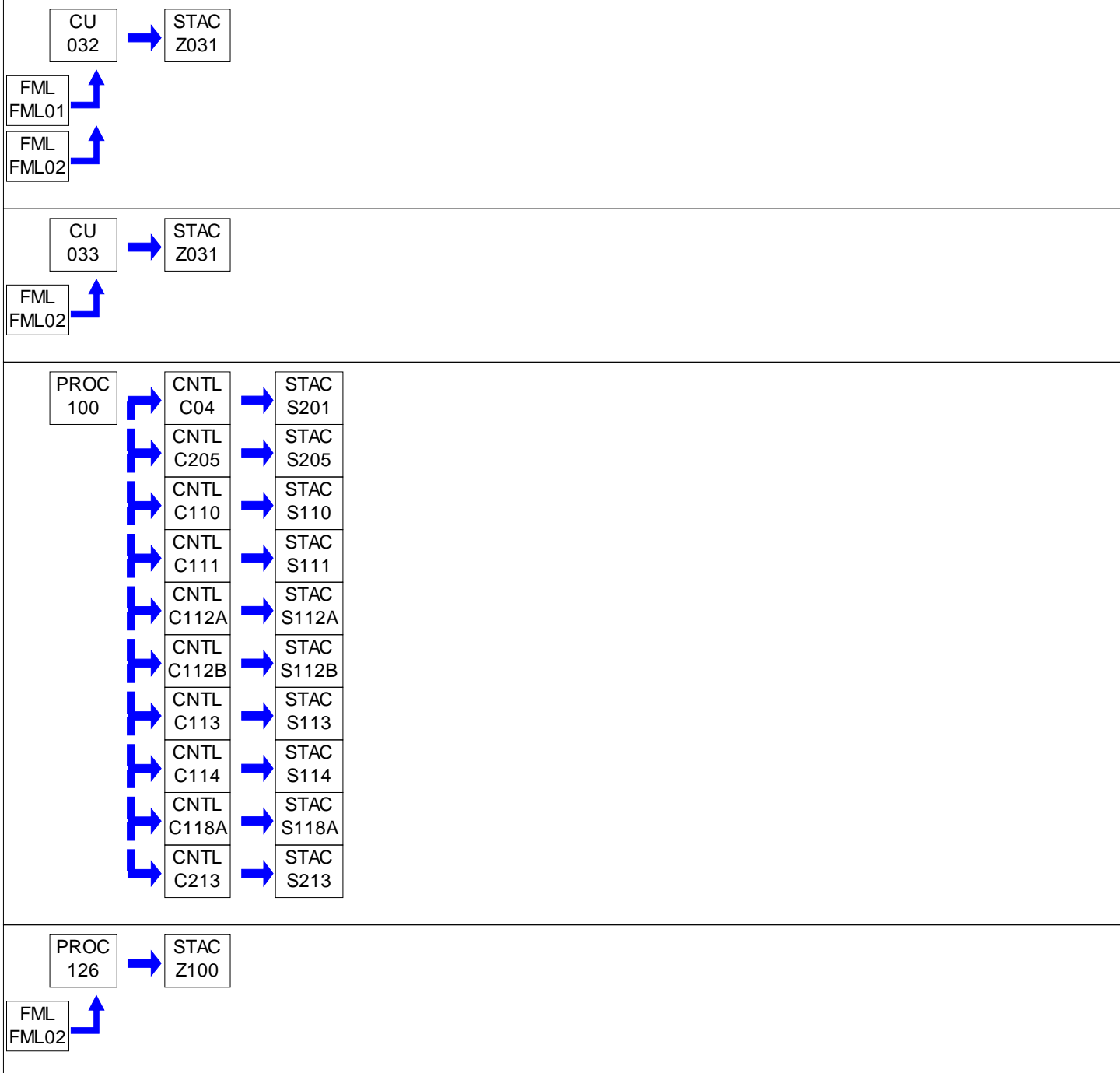
PERMIT MAPS



PERMIT MAPS

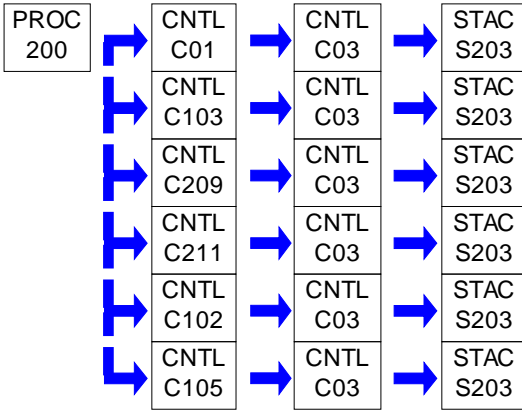

**SECTION B. General State Only Requirements****#001 [25 Pa. Code § 121.1]****Definitions.**

Words and terms that are not otherwise defined in this permit shall have the meanings set forth in Section 3 of the Air Pollution Control Act (35 P.S. § 4003) and in 25 Pa. Code § 121.1.

#002 [25 Pa. Code § 127.446]**Operating Permit Duration.**

(a) This operating permit is issued for a fixed term of five (5) years and shall expire on the date specified on Page 1 of this permit.

(b) The terms and conditions of the expired permit shall automatically continue pending issuance of a new operating permit, provided the permittee has submitted a timely and complete application and paid applicable fees required under 25 Pa. Code Chapter 127, Subchapter I and the Department is unable, through no fault of the permittee, to issue or deny a new permit before the expiration of the previous permit.

#003 [25 Pa. Code §§ 127.412, 127.413, 127.414, 127.446 & 127.703(b)]**Permit Renewal.**

(a) The permittee shall submit a timely and complete application for renewal of the operating permit to the appropriate Regional Air Program Manager. The application for renewal of the operating permit shall be submitted at least six (6) months and not more than 18 months before the expiration date of this permit.

(b) The application for permit renewal shall include the current permit number, a description of any permit revisions that occurred during the permit term, and any applicable requirements that were promulgated and not incorporated into the permit during the permit term. An application is complete if it contains sufficient information to begin processing the application, has the applicable sections completed and has been signed by a responsible official.

(c) The permittee shall submit with the renewal application a fee for the processing of the application as specified in 25 Pa. Code § 127.703(b). The fees shall be made payable to "The Commonwealth of Pennsylvania Clean Air Fund" and submitted with the fee form to the respective regional office.

(d) The renewal application shall also include submission of proof that the local municipality and county, in which the facility is located, have been notified in accordance with 25 Pa. Code § 127.413.

(e) The application for renewal of the operating permit shall also include submission of supplemental compliance review forms in accordance with the requirements of 25 Pa. Code § 127.412(b) and § 127.412(j).

(f) The permittee, upon becoming aware that any relevant facts were omitted or incorrect information was submitted in the permit application, shall promptly submit such supplementary facts or corrected information as necessary to address any requirements that become applicable to the source after the permittee submits a complete application, but prior to the date the Department takes action on the permit application.

#004 [25 Pa. Code § 127.703]**Operating Permit Fees under Subchapter F.**

(a) The permittee shall pay the annual operating permit maintenance fee according to the following fee schedule in either paragraph (1) or (2) in accordance with 25 Pa. Code § 127.703(d) on or before December 31 of each year for the next calendar year.

(1) For a synthetic minor facility, a fee equal to:

(i) Four thousand dollars (\$4,000) for calendar years 2021—2025.

(ii) Five thousand dollars (\$5,000) for calendar years 2026—2030.

(iii) Six thousand three hundred dollars (\$6,300) for the calendar years beginning with 2031.

(2) For a facility that is not a synthetic minor, a fee equal to:

**SECTION B. General State Only Requirements**

- (i) Two thousand dollars (\$2,000) for calendar years 2021—2025.
- (ii) Two thousand five hundred dollars (\$2,500) for calendar years 2026—2030.
- (iii) Three thousand one hundred dollars (\$3,100) for the calendar years beginning with 2031.

(b) The applicable fees shall be made payable to "The Commonwealth of Pennsylvania Clean Air Fund" with the permit number clearly indicated and submitted to the respective regional office.

#005 [25 Pa. Code §§ 127.450 (a)(4) and 127.464]**Transfer of Operating Permits.**

(a) This operating permit may not be transferred to another person, except in cases of transfer-of-ownership that are documented and approved by the Department.

(b) In accordance with 25 Pa. Code § 127.450(a)(4), a change in ownership of the source shall be treated as an administrative amendment if the Department determines that no other change in the permit is required and a written agreement has been submitted to the Department identifying the specific date of the transfer of permit responsibility, coverage and liability between the current and the new permittee and a compliance review form has been submitted to, and the permit transfer has been approved by, the Department.

(c) This operating permit is valid only for those specific sources and the specific source locations described in this permit.

#006 [25 Pa. Code § 127.441 and 35 P.S. § 4008]**Inspection and Entry.**

(a) Upon presentation of credentials and other documents as may be required by law, the permittee shall allow the Department or authorized representatives of the Department to perform the following:

(1) Enter at reasonable times upon the permittee's premises where a source is located or emissions related activity is conducted, or where records are kept under the conditions of this permit;

(2) Have access to and copy, at reasonable times, any records that are kept under the conditions of this permit;

(3) Inspect at reasonable times, any facilities, equipment including monitoring and air pollution control equipment, practices, or operations regulated or required under this permit;

(4) Sample or monitor, at reasonable times, any substances or parameters, for the purpose of assuring compliance with the permit or applicable requirements as authorized by the Clean Air Act, the Air Pollution Control Act, or the regulations promulgated under the Acts.

(b) Pursuant to 35 P.S. § 4008, no person shall hinder, obstruct, prevent or interfere with the Department or its personnel in the performance of any duty authorized under the Air Pollution Control Act or regulations adopted thereunder including denying the Department access to a source at this facility. Refusal of entry or access may constitute grounds for permit revocation and assessment of criminal and/or civil penalties.

(c) Nothing in this permit condition shall limit the ability of the EPA to inspect or enter the premises of the permittee in accordance with Section 114 or other applicable provisions of the Clean Air Act.

#007 [25 Pa. Code §§ 127.441 & 127.444]**Compliance Requirements.**

(a) The permittee shall comply with the conditions of this operating permit. Noncompliance with this permit constitutes a violation of the Clean Air Act and the Air Pollution Control Act and is grounds for one or more of the following:

- (1) Enforcement action

**SECTION B. General State Only Requirements**

(2) Permit termination, revocation and reissuance or modification

(3) Denial of a permit renewal application

(b) A person may not cause or permit the operation of a source which is subject to 25 Pa. Code Article III unless the source(s) and air cleaning devices identified in the application for the plan approval and operating permit and the plan approval issued for the source is operated and maintained in accordance with specifications in the applications and the conditions in the plan approval and operating permit issued by the Department. A person may not cause or permit the operation of an air contamination source subject to 25 Pa. Code Chapter 127 in a manner inconsistent with good operating practices.

(c) For purposes of Sub-condition (b) of this permit condition, the specifications in applications for plan approvals and operating permits are the physical configurations and engineering design details which the Department determines are essential for the permittee's compliance with the applicable requirements in this State-Only permit. Nothing in this sub-condition shall be construed to create an independent affirmative duty upon the permittee to obtain a predetermination from the Department for physical configuration or engineering design detail changes made by the permittee.

#008 [25 Pa. Code § 127.441]**Need to Halt or Reduce Activity Not a Defense.**

It shall not be a defense for the permittee in an enforcement action that it was necessary to halt or reduce the permitted activity in order to maintain compliance with the conditions of this permit.

#009 [25 Pa. Code §§ 127.442(a) & 127.461]**Duty to Provide Information.**

(a) The permittee shall submit reports to the Department containing information the Department may prescribe relative to the operation and maintenance of each source at the facility.

(b) The permittee shall furnish to the Department, in writing, information that the Department may request to determine whether cause exists for modifying, revoking and reissuing, or terminating this permit, or to determine compliance with the permit. Upon request, the permittee shall also furnish to the Department copies of records that the permittee is required to maintain in accordance with this permit.

#010 [25 Pa. Code § 127.461]**Revising an Operating Permit for Cause.**

This operating permit may be terminated, modified, suspended or revoked and reissued if one or more of the following applies:

(1) The permittee constructs or operates the source subject to the operating permit so that it is in violation of the Air Pollution Control Act, the Clean Air Act, the regulations thereunder, a plan approval, a permit or in a manner that causes air pollution.

(2) The permittee fails to properly or adequately maintain or repair an air pollution control device or equipment attached to or otherwise made a part of the source.

(3) The permittee has failed to submit a report required by the operating permit or an applicable regulation.

(4) The EPA determines that the permit is not in compliance with the Clean Air Act or the regulations thereunder.

#011 [25 Pa. Code §§ 127.450, 127.462, 127.465 & 127.703]**Operating Permit Modifications**

(a) The permittee is authorized to make administrative amendments, minor operating permit modifications and significant operating permit modifications, under this permit, as outlined below:

(b) Administrative Amendments. The permittee shall submit the application for administrative operating permit amendments (as defined in 25 Pa. Code § 127.450(a)), according to procedures specified in § 127.450 unless

**SECTION B. General State Only Requirements**

precluded by the Clean Air Act or its regulations.

(c) Minor Operating Permit Modifications. The permittee shall submit the application for minor operating permit modifications (as defined 25 Pa. Code § 121.1) in accordance with 25 Pa. Code § 127.462.

(d) Significant Operating Permit Modifications. The permittee shall submit the application for significant operating permit modifications in accordance with 25 Pa. Code § 127.465.

(e) The applicable fees shall be made payable to "The Commonwealth of Pennsylvania Clean Air Fund" with the permit number clearly indicated and submitted to the respective regional office.

#012 [25 Pa. Code § 127.441]**Severability Clause.**

The provisions of this permit are severable, and if any provision of this permit is determined by a court of competent jurisdiction to be invalid or unenforceable, such a determination will not affect the remaining provisions of this permit.

#013 [25 Pa. Code § 127.449]**De Minimis Emission Increases.**

(a) This permit authorizes de minimis emission increases in accordance with 25 Pa. Code § 127.449 so long as the permittee provides the Department with seven (7) days prior written notice before commencing any de minimis emissions increase. The written notice shall:

(1) Identify and describe the pollutants that will be emitted as a result of the de minimis emissions increase.

(2) Provide emission rates expressed in tons per year and in terms necessary to establish compliance consistent with any applicable requirement.

(b) The Department may disapprove or condition de minimis emission increases at any time.

(c) Except as provided below in (d), the permittee is authorized to make de minimis emission increases (expressed in tons per year) up to the following amounts without the need for a plan approval or prior issuance of a permit modification:

(1) Four tons of carbon monoxide from a single source during the term of the permit and 20 tons of carbon monoxide at the facility during the term of the permit.

(2) One ton of NO_x from a single source during the term of the permit and 5 tons of NO_x at the facility during the term of the permit.

(3) One and six-tenths tons of the oxides of sulfur from a single source during the term of the permit and 8.0 tons of oxides of sulfur at the facility during the term of the permit.

(4) Six-tenths of a ton of PM₁₀ from a single source during the term of the permit and 3.0 tons of PM₁₀ at the facility during the term of the permit. This shall include emissions of a pollutant regulated under Section 112 of the Clean Air Act unless precluded by the Clean Air Act, the regulations thereunder or 25 Pa. Code Article III.

(5) One ton of VOCs from a single source during the term of the permit and 5.0 tons of VOCs at the facility during the term of the permit. This shall include emissions of a pollutant regulated under Section 112 of the Clean Air Act unless precluded by the Clean Air Act, the regulations thereunder or 25 Pa. Code Article III.

(6) Other sources and classes of sources determined to be of minor significance by the Department.

(d) In accordance with § 127.14, the permittee is authorized to install the following minor sources without the need for a plan approval or permit modification:

(1) Air conditioning or ventilation systems not designed to remove pollutants generated or released from other sources.

**SECTION B. General State Only Requirements**

(2) Combustion units rated at 2,500,000 or less Btu per hour of heat input.

(3) Combustion units with a rated capacity of less than 10,000,000 Btu per hour heat input fueled by natural gas supplied by a public utility or by commercial fuel oils which are No. 2 or lighter, viscosity less than or equal to 5.82 c St, and which meet the sulfur content requirements of 25 Pa. Code §123.22 (relating to combustion units). For purposes of this permit, commercial fuel oil shall be virgin oil which has no reprocessed, recycled or waste material added.

(4) Space heaters which heat by direct heat transfer.

(5) Laboratory equipment used exclusively for chemical or physical analysis.

(6) Other sources and classes of sources determined to be of minor significance by the Department.

(e) This permit does not authorize de minimis emission increases if the emissions increase would cause one or more of the following:

(1) Increase the emissions of a pollutant regulated under Section 112 of the Clean Air Act except as authorized in Subparagraphs (c)(4) and (5) of this permit condition.

(2) Subject the facility to the prevention of significant deterioration requirements in 25 Pa. Code Chapter 127, Subchapter D and/or the new source review requirements in Subchapter E.

(3) Violate any applicable requirement of this permit, the Air Pollution Control Act, the Clean Air Act, or the regulations promulgated under either of the acts.

(f) Emissions authorized under this permit condition shall be included in the monitoring, recordkeeping and reporting requirements of this permit.

(g) Except for de minimis emission increases, installation of minor sources made pursuant to this permit condition and Plan Approval Exemptions under 25 Pa. Code § 127.14 (relating to exemptions), the permittee is prohibited from making changes or engaging in activities that are not specifically authorized under this permit without first applying for a plan approval. In accordance with § 127.14(b), a plan approval is not required for the construction, modification, reactivation, or installation of the sources creating the de minimis emissions increase.

(h) The permittee may not meet de minimis emission threshold levels by offsetting emission increases or decreases at the same source.

#014 [25 Pa. Code § 127.3]**Operational Flexibility.**

The permittee is authorized to make changes within the facility in accordance with the regulatory provisions outlined in 25 Pa. Code § 127.3 (relating to operational flexibility) to implement the operational flexibility requirements provisions authorized under Section 6.1(i) of the Air Pollution Control Act and the operational flexibility terms and conditions of this permit. The provisions in 25 Pa. Code Chapter 127 which implement the operational flexibility requirements include the following:

(1) Section 127.14 (relating to exemptions)

(2) Section 127.447 (relating to alternative operating scenarios)

(3) Section 127.448 (relating to emissions trading at facilities with Federally enforceable emissions caps)

(4) Section 127.449 (relating to de minimis emission increases)

(5) Section 127.450 (relating to administrative operating permit amendments)

(6) Section 127.462 (relating to minor operating permit modifications)

(7) Subchapter H (relating to general plan approvals and general operating permits)

**SECTION B. General State Only Requirements****#015 [25 Pa. Code § 127.11a]****Reactivation of Sources**

(a) The permittee may not reactivate a source that has been out of operation or production for at least one year unless the reactivation is conducted in accordance with a plan approval granted by the Department or in accordance with reactivation and maintenance plans developed and approved by the Department in accordance with 25 Pa. Code § 127.11a(a).

(b) A source which has been out of operation or production for more than five (5) years but less than 10 years may be reactivated and will not be considered a new source if the permittee satisfies the conditions specified in 25 Pa. Code § 127.11a(b).

#016 [25 Pa. Code § 127.36]**Health Risk-based Emission Standards and Operating Practice Requirements.**

(a) When needed to protect public health, welfare and the environment from emissions of hazardous air pollutants from new and existing sources, the permittee shall comply with the health risk-based emission standards or operating practice requirements imposed by the Department, except as precluded by §§ 6.6(d)(2) and (3) of the Air Pollution Control Act [35 P.S. § 4006.6(d)(2) and (3)].

(b) A person challenging a performance or emission standard established by the Department has the burden to demonstrate that performance or emission standard does not meet the requirements of Section 112 of the Clean Air Act.

#017 [25 Pa. Code § 121.9]**Circumvention.**

No person may permit the use of a device, stack height which exceeds good engineering practice stack height, dispersion technique or other technique which, without resulting in reduction of the total amount of air contaminants emitted, conceals or dilutes an emission of air contaminants which would otherwise be in violation of 25 Pa. Code Article III, except that with prior approval of the Department, the device or technique may be used for control of malodors.

#018 [25 Pa. Code §§ 127.402(d) & 127.442]**Reporting Requirements.**

(a) The permittee shall comply with the applicable reporting requirements of the Clean Air Act, the regulations thereunder, the Air Pollution Control Act and 25 Pa. Code Article III including Chapters 127, 135 and 139.

(b) The permittee shall submit reports to the Department containing information the Department may prescribe relative to the operation and maintenance of any air contamination source.

(c) Reports, test data, monitoring data, notifications and requests for renewal of the permit shall be submitted to the:

Regional Air Program Manager
PA Department of Environmental Protection
(At the address given in the permit transmittal letter, or otherwise notified)

(d) Any records or information including applications, forms, or reports submitted pursuant to this permit condition shall contain a certification by a responsible official as to truth, accuracy and completeness. The certifications submitted under this permit shall require a responsible official of the facility to certify that based on information and belief formed after reasonable inquiry, the statements and information in the documents are true, accurate and complete.

(e) Any records, reports or information submitted to the Department shall be available to the public except for such records, reports or information which meet the confidentiality requirements of § 4013.2 of the Air Pollution Control Act and §§ 112(d) and 114(c) of the Clean Air Act. The permittee may not request a claim of confidentiality for any emissions data generated for the facility.

**SECTION B. General State Only Requirements****#019 [25 Pa. Code §§ 127.441(c) & 135.5]****Sampling, Testing and Monitoring Procedures.**

(a) The permittee shall comply with the monitoring, recordkeeping or reporting requirements of 25 Pa. Code Chapter 139 and the other applicable requirements of 25 Pa. Code Article III and additional requirements related to monitoring, reporting and recordkeeping required by the Clean Air Act and the regulations thereunder including the Compliance Assurance Monitoring requirements of 40 CFR Part 64, where applicable.

(b) Unless alternative methodology is required by the Clean Air Act and regulations adopted thereunder, sampling, testing and monitoring required by or used by the permittee to demonstrate compliance with any applicable regulation or permit condition shall be conducted in accordance with the requirements of 25 Pa. Code Chapter 139.

#020 [25 Pa. Code §§ 127.441(c) and 135.5]**Recordkeeping.**

(a) The permittee shall maintain and make available, upon request by the Department, the following records of monitored information:

- (1) The date, place (as defined in the permit) and time of sampling or measurements.
- (2) The dates the analyses were performed.
- (3) The company or entity that performed the analyses.
- (4) The analytical techniques or methods used.
- (5) The results of the analyses.
- (6) The operating conditions as existing at the time of sampling or measurement.

(b) The permittee shall retain records of any required monitoring data and supporting information for at least five (5) years from the date of the monitoring, sample, measurement, report or application. Supporting information includes the calibration data and maintenance records and original strip-chart recordings for continuous monitoring instrumentation, and copies of reports required by the permit.

(c) The permittee shall maintain and make available to the Department upon request, records including computerized records that may be necessary to comply with the reporting, recordkeeping and emission statement requirements in 25 Pa. Code Chapter 135 (relating to reporting of sources). In accordance with 25 Pa. Code Chapter 135, § 135.5, such records may include records of production, fuel usage, maintenance of production or pollution control equipment or other information determined by the Department to be necessary for identification and quantification of potential and actual air contaminant emissions.

#021 [25 Pa. Code § 127.441(a)]**Property Rights.**

This permit does not convey any property rights of any sort, or any exclusive privileges.

#022 [25 Pa. Code § 127.447]**Alternative Operating Scenarios.**

The permittee is authorized to make changes at the facility to implement alternative operating scenarios identified in this permit in accordance with 25 Pa. Code § 127.447.

#023 [25 Pa. Code § 121.7]**Prohibition of Air Pollution**

No person may permit air pollution as that term is defined in the Air Pollution Control Act (35 P.S. §§ 4001-4015).

**SECTION B. General State Only Requirements****#024 [25 Pa. Code §135.3]****Reporting**

(a) If the facility is a Synthetic Minor Facility, the permittee shall submit by March 1 of each year an annual emissions report for the preceding calendar year. The report shall include information for all active previously reported sources, new sources which were first operated during the preceding calendar year, and sources modified during the same period which were not previously reported. All air emissions from the facility should be estimated and reported.

(b) A source owner or operator of a Synthetic Minor Facility may request an extension of time from the Department for the filing of an annual emissions report, and the Department may grant the extension for reasonable cause.

#025 [25 Pa. Code §135.4]**Report Format**

If applicable, the emissions reports shall contain sufficient information to enable the Department to complete its emission inventory. Emissions reports shall be made by the source owner or operator in a format specified by the Department.

**SECTION C. Site Level Requirements****I. RESTRICTIONS.****Emission Restriction(s).****# 001 [25 Pa. Code §121.7]****Prohibition of air pollution.**

No person may permit air pollution as that term is defined in the Air Pollution Control Act (35 P.S. Section 4003).

002 [25 Pa. Code §123.1]**Prohibition of certain fugitive emissions**

No person may permit the emission into the outdoor atmosphere of fugitive air contaminant from a source other than the following:

- (1) Construction or demolition of buildings or structures.
- (2) Grading, paving and maintenance of roads and streets.
- (3) Use of roads and streets. Emissions from material in or on trucks, railroad cars and other vehicular equipment are not considered as emissions from use of roads and streets.
- (4) Clearing of land.
- (5) Stockpiling of materials.
- (6) Open burning operations, as specified in 25 Pa. Code § 129.14.
- (7) N/A
- (8) N/A
- (9) Sources and classes of sources other than those identified in (1)-(8) above, for which the permittee has obtained a determination from the Department that fugitive emissions from the source, after appropriate control, meet the following requirements:

(i) The emissions are of minor significance with respect to causing air pollution; and

(ii) The emissions are not preventing or interfering with the attainment or maintenance of any ambient air quality standard.

003 [25 Pa. Code §123.2]**Fugitive particulate matter**

A person may not permit fugitive particulate matter to be emitted into the outdoor atmosphere from a source specified in 25 Pa. Code § 123.1(a)(1) - (9), relating to prohibition of certain fugitive emissions, if such emissions are visible at the point the emissions pass outside the person's property.

004 [25 Pa. Code §123.31]**Limitations**

A person may not permit the emission into the outdoor atmosphere of any malodorous air contaminants from any source in such a manner that the malodors are detectable outside the property of the person on whose land the source is being operated.

005 [25 Pa. Code §123.41]**Limitations**

A person may not permit the emission into the outdoor atmosphere of visible air contaminants in such a manner that the opacity of the emission is either of the following:

(a) Equal to or greater than 20% for a period or periods aggregating more than three minutes in any 1 hour.

(b) Equal to or greater than 60% at any time.

006 [25 Pa. Code §123.42]**Exceptions**

The opacity limitations of 25 Pa. Code § 123.41 shall not apply to a visible emission in any of the following instances:

(a) When the presence of uncombined water is the only reason for failure of the emission to meet the limitations.

(b) When the emission results from the operation of equipment used solely to train and test persons in observing the opacity of visible emissions.

(c) When the emission results from sources specified in 25 Pa. Code § 123.1(a)(1) -- (9) (relating to prohibition of certain

**SECTION C. Site Level Requirements**

fugitive emissions).

007 [25 Pa. Code §127.441]**Operating permit terms and conditions.**

(a) The permittee shall limit facility-wide VOC emissions to less than 25 tons per year, calculated as a 12-month rolling sum.

(b) The permittee shall limit the total VOC emissions from all sources at the facility, as follows:

- (1) Plastic Masterbatch Center/Dry Building (Source ID 100): 6.75 tons/year
- (2) Liquid Dispersion Center/Wet Building (Source ID 200): 13.9 tons/year
- (3) All Auxiliary/Miscellaneous Sources (AIMS Source ID 120): 3.25 tons/year

(c) The Liquid Dispersion Center/Wet Building (Source ID 200) post-control VOC emission limit of 13.9 tons/year shall include any VOC containing solvent added to the process and used in clean up operations.

(d) All auxiliary/miscellaneous sources are those listed in the Miscellaneous Section of the facility-wide operating permit as well as degreasers (Source ID 204) and emergency generators (Source ID 126).

(e) The permittee shall limit facility-wide Hazardous Air Pollutant (HAP) emissions as follows:

- (1) 9.9 tons per year of each individual HAP, or less, calculated as a 12-month rolling sum; and
- (2) 24.9 tons per year of any combination of HAPs, or less, calculated as a 12-month rolling sum.

(f) The permittee shall limit facility-wide Nitrogen Oxides (NOx) emissions to less than 25 tons per year, calculated as a 12-month rolling sum.

(g) The permittee shall limit facility-wide Particulate Matter (PM) emissions to less than 100 tons per year, calculated as a 12-month rolling sum.

(h) Facility-wide emission limits include emissions from all sources listed in Section A of this permit, as well as miscellaneous sources exempt from plan approval requirements which are listed in Section H of this permit.

008 [25 Pa. Code §129.14]**Open burning operations**

No person may permit the open burning of material in the Southeast Air Basin except when the open burning operations result from:

- (a) A fire set to prevent or abate a fire hazard, when approved by the Department and set by or under the supervision of a public officer.
- (b) Any fire set for the purpose of instructing personnel in fire fighting, when approved by the Department.
- (c) A fire set for the prevention and control of disease or pests, when approved by the Department.
- (d) A fire set in conjunction with the production of agricultural commodities in their unmanufactured state on the premises of the farm operation.
- (e) A fire set for the purpose of burning domestic refuse, when the fire is on the premises of a structure occupied solely as a dwelling by two families or less and when the refuse results from the normal occupancy of the structure.
- (f) A fire set solely for recreational or ceremonial purposes.
- (g) A fire set solely for cooking food.

Throughput Restriction(s).**# 009 [25 Pa. Code §127.441]****Operating permit terms and conditions.**

The permittee shall limit the total amount of fuel consumed as follows:

**SECTION C. Site Level Requirements**

- (a) Natural gas: 325 MMCF per year
- (b) No. Fuel Oil in Boilers: 100,000 gallons per year
- (c) Diesel in emergency generators: 20,900 gallons per year.

II. TESTING REQUIREMENTS.**# 010 [25 Pa. Code §127.441]****Operating permit terms and conditions.**

(a) The permittee shall email all source test submissions (notifications, protocols, reports, supplemental information, etc.) to both the AQ Program Manager for the Southeast Regional Office and the PSIMS Administrator in Central Office (email addresses are provided below). Any questions or concerns about source testing submissions can be sent to RA-EPstacktesting@pa.gov and the PSIMS Administrator will address them.

Southeast Region
RA-EPSEstacktesting@pa.gov

Central Office
RA-EPstacktesting@pa.gov

(b) The following pertinent information shall be listed on the title page.

1. Test Date(s)

- a. For protocols, provide the proposed date on which testing will commence or "TBD"
- b. For reports, provide the first and last day of testing

2. Facility Identification Number (Facility - PF ID 628285): For test programs that were conducted under a multi-site protocol, also include the PF ID under which the protocol was stored in PSIMS, as indicated in the protocol response letter.

3. Source ID(s) for the applicable source(s) and air pollution control device(s): The term Source ID is used in the permit but "Other Id" is used in DEP electronic systems. They are the same number and must also be listed for control equipment

4. Testing Requirements (all that apply) engineer:

- a. Plan approval number(s)
- b. Operating permit number
- c. Applicable federal subpart(s)
- d. Special purpose(s) (Consent Order, RFD, RACT II, Tier II, etc.)

(c) If confidential information must be submitted, submit both a public copy, which has been redacted, and a confidential copy. The cover page of each submittal should state whether it is a "Public Copy" or "Confidential Copy" and each page of the latter must be marked "CONFIDENTIAL".

011 [25 Pa. Code §127.441]**Operating permit terms and conditions.**

(a) If at any time the Department has cause to believe that air contaminant emissions from any source may be in excess of the limitations specified in this operating permit or established pursuant to any applicable rule or regulation contained in 25 Pa. Code Article III, the permittee shall be required to conduct whatever tests are deemed necessary by the Department to determine the actual emission rate(s).

(b) Such testing shall be conducted in accordance with the provisions of 25 Pa. Code Chapter 139 and the most current version of the DEP Source Testing Manual, when applicable, and in accordance with any restrictions or limitations established by the Department at such time as it notifies the permittee that testing is required.

**SECTION C. Site Level Requirements****III. MONITORING REQUIREMENTS.****# 012 [25 Pa. Code §123.43]****Measuring techniques**

Visible emissions may be measured using either of the following:

- (a) A device approved by the Department and maintained to provide accurate opacity measurements.
- (b) Observers, trained and qualified to measure plume opacity with the naked eye or with the aid of any devices approved by the Department.

013 [25 Pa. Code §127.441]**Operating permit terms and conditions.**

(a) The permittee shall monitor the facility, once per operating day, for the following:

- (1) Odors which may be objectionable (as per 25 Pa. Code §123.31).
- (2) Visible Emissions (as per 25 Pa. Code §§123.41 and 123.42).
- (3) Fugitive Particulate Matter (as per 25 Pa. Code §§ 123.1 and 123.2).

(b) Objectionable odors, fugitive particulate emissions, and visible emissions that are caused or may be caused by operations at the site shall:

- (1) Be investigated;
- (2) Be reported to the facility management, or individual(s) designated by the permittee;
- (3) Have appropriate corrective action taken (for emissions that originate on-site); and
- (4) Be recorded in a permanent written log.

(c) After six (6) months of daily monitoring, and upon the permittee's request, the Department will determine the feasibility of decreasing the monitoring frequency to weekly.

(d) After six (6) months of weekly monitoring, and upon the permittee's request, the Department will determine the feasibility of decreasing the frequency of monitoring to monthly.

(e) The Department reserves the right to change the above monitoring requirements at any time, based on but not limited to: the review of the compliance certification, complaints, monitoring results, and/or Department findings.

IV. RECORDKEEPING REQUIREMENTS.**# 014 [25 Pa. Code §127.441]****Operating permit terms and conditions.**

The permittee shall maintain records of all the facility's increases of emissions from the following categories:

- (a) de minimis increases without notification to the Department;
- (b) de minimis increases with notification to the Department, via letter;
- (c) increases resulting from a Request for Determination (RFD) to the Department; and
- (d) increases resulting from the issuance of a plan approval and subsequent operating permit.

015 [25 Pa. Code §127.441]**Operating permit terms and conditions.**

(a) The permittee shall record sufficient data so that compliance with the facility-wide emission restrictions can be determined. Records shall be kept for a minimum of five (5) years and shall be made available to the Department upon request.

(b) The permittee shall maintain records of facility-wide VOC, HAP, NO_x, and PM emissions on a monthly basis, calculated as a 12-month rolling sum, in order to ensure compliance with the applicable facility-wide annual emission limitations of this Operating Permit.

(c) Facility-wide emissions include emissions from all sources listed in Section A of this permit, as well as miscellaneous sources exempt from plan approval requirements which are listed in Section H of this permit.

**SECTION C. Site Level Requirements****# 016 [25 Pa. Code §127.441]****Operating permit terms and conditions.**

The permittee shall maintain a record of all monitoring of fugitive emissions, visible emissions and odors, including those that deviate from the conditions found in this permit. The record of deviations shall contain, at a minimum, the following items:

- (a) Date, time, and location of the incident(s).
- (b) The cause of the event.
- (c) The corrective action taken, if necessary, to abate the situation and prevent future occurrences.

017 [25 Pa. Code §127.441]**Operating permit terms and conditions.**

(a) The permittee shall maintain records of the total amount of natural gas used on a monthly basis and 12-month rolling sum basis.

(b) The permittee shall maintain records of the total amount of No. 2 fuel oil used in all boilers on site on a monthly basis and 12-month rolling sum.

(c) The permittee shall maintain records of the total amount of diesel fuel oiler used in all emergency generators on site on a monthly basis and 12-month rolling sum.

V. REPORTING REQUIREMENTS.**# 018 [25 Pa. Code §127.441]****Operating permit terms and conditions.**

(a) The permittee shall report malfunctions, emergencies or incidents of excess emissions to the Department at 484-250-5920. A malfunction is any sudden, infrequent, and not reasonably preventable failure of air pollution control equipment, process equipment, or a process to operate in a normal or usual manner. An emergency is any situation arising from sudden and reasonably unforeseeable events beyond the control of the owner or operator of a facility which requires immediate corrective action to restore normal operation and which causes the emission source to exceed emissions, due to unavoidable increases in emissions attributable to the situation. An emergency shall not include situations caused by improperly designed equipment, lack of preventive maintenance, careless or improper operation, or operator error.

(b) When the malfunction, emergency or incident of excess emissions poses an imminent danger to the public health, safety, welfare, or environment, it shall be reported to the Department and the County Emergency Management Agency by telephone within one (1) hour after the discovery of the malfunction, emergency or incident of excess emissions. The owner or operator shall submit a written or emailed report of instances of such malfunctions, emergencies or incidents of excess emissions to the Department within three (3) business days of the telephone report.

(c) The report shall describe the following:

- (1) Name, permit or authorization number, and location of the facility;
- (2) Nature and cause of the malfunction, emergency or incident;
- (3) Date and time when the malfunction, emergency or incident was first observed;
- (4) Expected duration of excess emissions;
- (5) Estimated rate of emissions; and
- (6) Corrective actions or preventative measures taken.

(d) Any malfunction, emergency or incident of excess emissions that is not subject to the notice requirements of paragraph (b) of this condition shall be reported to the Department by telephone within 24 hours (or by 4:00 PM of the next business day, whichever is later) of discovery and in writing or by e-mail within five (5) business days of discovery. The report shall contain the same information required by paragraph (c), and any permit specific malfunction reporting requirements.

(e) During an emergency an owner or operator may continue to operate the source at their discretion provided they submit justification for continued operation of a source during the emergency and follow all the notification and reporting requirements in accordance with paragraphs (b)-(d), as applicable, including any permit specific malfunction reporting

**SECTION C. Site Level Requirements**

requirements.

(f) Reports regarding malfunctions, emergencies or incidents of excess emissions shall be submitted to the appropriate DEP Regional Office Air Program Manager.

(g) Any emissions resulted from malfunction or emergency are to be reported in the annual emissions inventory report, if the annual emissions inventory report is required by permit or authorization.

019 [25 Pa. Code §127.441]**Operating permit terms and conditions.**

[Additional authority for this permit condition is also derived from 40 CFR Part 68.]

(a) If required by Section 112(r) of the Clean Air Act, the permittee shall develop and implement an accidental release program consistent with requirements of the Clean Air Act, 40 CFR Part 68 (relating to chemical accident prevention provisions) and the Federal Chemical Safety Information, Site Security and Fuels Regulatory Relief Act (P.L. 106-40).

(b) The permittee shall prepare and implement a Risk Management Plan (RMP) which meets the requirements of Section 112(r) of the Clean Air Act, 40 CFR Part 68 and the Federal Chemical Safety Information, Site Security and Fuels Regulatory Relief Act when a regulated substance listed in 40 CFR § 68.130 is present in a process in more than the threshold quantity at a facility. The permittee shall submit the RMP to the federal Environmental Protection Agency according to the following schedule and requirements:

(1) The permittee shall submit the first RMP to a central point specified by EPA no later than the latest of the following:

- (i) Three years after the date on which a regulated substance is first listed under 40 CFR § 68.130; or,
- (ii) The date on which a regulated substance is first present above a threshold quantity in a process.

(2) The permittee shall submit any additional relevant information requested by the Department or EPA concerning the RMP and shall make subsequent submissions of RMPs in accordance with 40 CFR § 68.190.

(3) The permittee shall certify that the RMP is accurate and complete in accordance with the requirements of 40 CFR Part 68, including a checklist addressing the required elements of a complete RMP.

(c) As used in this permit condition, the term "process" shall be as defined in 40 CFR § 68.3. The term "process" means any activity involving a regulated substance including any use, storage, manufacturing, handling, or on-site movement of such substances or any combination of these activities. For purposes of this definition, any group of vessels that are interconnected, or separate vessels that are located such that a regulated substance could be involved in a potential release, shall be considered a single process.

(d) If this facility is subject to 40 CFR Part 68, as part of the certification required under this permit, the permittee shall:

(1) Submit a compliance schedule for satisfying the requirements of 40 CFR Part 68 by the date specified in 40 CFR § 68.10(a); or,

(2) Certify that this facility is in compliance with all requirements of 40 CFR Part 68 including the registration and submission of the RMP.

(e) If this facility is subject to 40 CFR Part 68, the permittee shall maintain records supporting the implementation of an accidental release program for five (5) years in accordance with 40 CFR § 68.200.

(f) When this facility is subject to the accidental release program requirements of Section 112(r) of the Clean Air Act and 40 CFR Part 68, appropriate enforcement action will be taken by the Department if the permittee fails to register and submit the RMP or a revised plan pursuant to 40 CFR Part 68.

**SECTION C. Site Level Requirements****VI. WORK PRACTICE REQUIREMENTS.****# 020 [25 Pa. Code §123.1]****Prohibition of certain fugitive emissions**

A person responsible for any source specified in 25 Pa. Code § 123.1 shall take all reasonable actions to prevent particulate matter from becoming airborne. These actions shall include, but not be limited to, the following:

- (a) Use, where possible, of water or suitable chemicals, for control of dust in the demolition of buildings or structures, construction operations, the grading of roads, or the clearing of land.
- (b) Application of asphalt, water, or other suitable chemicals, on dirt roads, material stockpiles and other surfaces which may give rise to airborne dusts.
- (c) Paving and maintenance of roadways.
- (d) Prompt removal of earth or other material from paved streets onto which earth or other material has been transported by trucking or earth moving equipment, erosion by water, or by other means.

021 [25 Pa. Code §127.441]**Operating permit terms and conditions.**

The permittee shall ensure that all sources and air cleaning devices are operated and maintained in accordance with manufacturer's specifications and/or the facility's work practice standards and good engineering and air pollution control practices.

022 [25 Pa. Code §127.441]**Operating permit terms and conditions.**

The permittee shall maintain all covers or lids in good condition on pots and/or containers that contain VOC, such that when in place, the covers or lids maintain contact with the rim of the opening for at least 90 percent of the circumference of the rim.

023 [25 Pa. Code §127.441]**Operating permit terms and conditions.**

- (a) The permittee may not modify any air contaminant system identified in this permit prior to obtaining Department approval except those modifications authorized by Condition #013(g) of Section B of this permit.
- (b) The permittee shall immediately, upon discovery, implement measures which may include the application for the installation of an air cleaning device(s), if necessary, to reduce the air contaminant emissions to within applicable limitations, if at any time the operation of the source(s) identified in Section A of this permit is causing the emission of air contaminants in excess of the limitations specified in or established pursuant to 25 Pa. Code Article III or any other applicable rule promulgated under the Clean Air Act.

VII. ADDITIONAL REQUIREMENTS.

No additional requirements exist except as provided in other sections of this permit including Section B (State Only General Requirements).

VIII. COMPLIANCE CERTIFICATION.

No additional compliance certifications exist except as provided in other sections of this permit including Section B (relating to State Only General Requirements).

IX. COMPLIANCE SCHEDULE.

No compliance milestones exist.

**SECTION D. Source Level Requirements**

Source ID: 032

Source Name: DUAL FUEL BOILERS (NG AND NO. 2)

Source Capacity/Throughput:

N/A

Natural Gas

N/A

#2 Oil

Conditions for this source occur in the following groups: GROUP 4

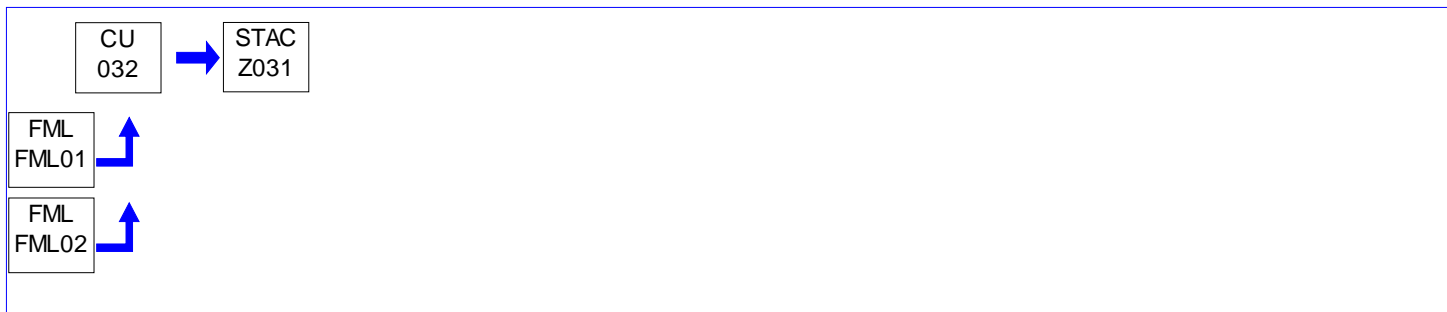
**I. RESTRICTIONS.****Fuel Restriction(s).****# 001 [25 Pa. Code §127.441]****Operating permit terms and conditions.**

The permittee shall burn natural gas or No. 2 fuel oil only in these boilers.

002 Elective Restriction

[Authority for this permit condition is derived from 25 Pa. Code § 127.35 and 40 CFR § 63.11194(d) and § 63.11195(e).]

(a) This boiler shall burn gaseous fuels not combined with any solid fuels, and liquid fuel only during periods of gas curtailment, gas supply emergencies, or periodic testing on liquid fuel. Periodic testing of liquid fuel shall not exceed a combined total of 48 hours during any calendar year.

(b) Fuel switching from natural gas to solid fossil fuel, biomass, or liquid fuel will result in the facility being subjected to 40 CFR § 63 Subpart JJJJJ: National Emission Standards for Hazardous Air Pollutants for Industrial, Commercial, and Institutional Boilers located at Area Sources.

II. TESTING REQUIREMENTS.

No additional testing requirements exist except as provided in other sections of this permit including Section B (State Only General Requirements) and/or Section E (Source Group Restrictions).

III. MONITORING REQUIREMENTS.

No additional monitoring requirements exist except as provided in other sections of this permit including Section B (State Only General Requirements) and/or Section E (Source Group Restrictions).

IV. RECORDKEEPING REQUIREMENTS.**# 003 [25 Pa. Code §127.441]****Operating permit terms and conditions.**

The permittee maintain monthly records of the amount and type of fuel consumed in the boilers listed in Source ID 032.

V. REPORTING REQUIREMENTS.**# 004 Elective Restriction**

[Authority for this permit condition is derived from 25 Pa. Code § 127.35 and 40 CFR § 63.11225(g).]

**SECTION D. Source Level Requirements**

(a) The permittee shall notify the Department and the USEPA of fuel switching from natural gas to liquid fuel other than liquid fuel consumption during periods of gas curtailment, gas supply emergencies, or periodic testing on liquid fuel.

(b) The permittee shall provide notice of the date upon which the switched occurred within 30 days of the change. The notification must identify:

(1) The name of the owner or operator of the affected source, the location of the source, the boiler(s) that have switched fuels, were physically changed, or took a permit limit, and the date of the notice.

(2) The date upon which the fuel switch, physical change, or permit limit occurred.

VI. WORK PRACTICE REQUIREMENTS.

No additional work practice requirements exist except as provided in other sections of this permit including Section B (State Only General Requirements) and/or Section E (Source Group Restrictions).

VII. ADDITIONAL REQUIREMENTS.

005 [25 Pa. Code §127.441]

Operating permit terms and conditions.

Source ID 032 contains the following dual fuel boilers:

1-VES-001 located in the Steam Boiler Room (Boiler #1): 4.184 MMBtu/hr Cleaver Brooks Boiler, Model No. CB-200-100, installed in 2008.

2-VES-004 located in the Boiler Room (Production Hot Water, Boiler #1): 5.23 MMBtu/hr Superior Boiler, Catalog No. 14562, installed in 2000.

**SECTION D. Source Level Requirements**

Source ID: 033

Source Name: NO. 2 FUEL OIL BOILERS

Source Capacity/Throughput:

N/A

#2 Oil

Conditions for this source occur in the following groups: GROUP 4

**I. RESTRICTIONS.****Fuel Restriction(s).****# 001 [25 Pa. Code §127.441]****Operating permit terms and conditions.**

The permittee shall burn No. 2 fuel oil only in the boilers listed in Source ID 033.

II. TESTING REQUIREMENTS.

No additional testing requirements exist except as provided in other sections of this permit including Section B (State Only General Requirements) and/or Section E (Source Group Restrictions).

III. MONITORING REQUIREMENTS.

No additional monitoring requirements exist except as provided in other sections of this permit including Section B (State Only General Requirements) and/or Section E (Source Group Restrictions).

IV. RECORDKEEPING REQUIREMENTS.**# 002 [40 CFR Part 63 NESHAPS for Source Categories §40 CFR 63.11223]****Subpart JJJJJJ - National Emission Standards for Hazardous Air Pollutants for Industrial, Commercial, and Institutional Boilers Area Sources****How do I demonstrate continuous compliance with the work practice and management practice standards?**

[Additional authority for this permit condition is also derived from 25 Pa. Code § 127.35.]

The permittee shall maintain on-site and submit, if requested by the Department or the USEPA, a copy of each tune-up report containing the following information:

- (a) The concentrations of CO in the effluent stream in parts per million, by volume, and oxygen in volume percent, measured at high fire or typical operating load, before and after the tune-up of the boiler.
- (b) A description of any corrective actions taken as a part of the tune-up of the boiler.
- (c) The type and amount of fuel used over the 12 months prior to the tune-up of the boiler, but only if the unit was physically and legally capable of using more than one type of fuel during that period. Units sharing a fuel meter may estimate the fuel use by each unit.

003 [40 CFR Part 63 NESHAPS for Source Categories §40 CFR 63.11225]**Subpart JJJJJJ - National Emission Standards for Hazardous Air Pollutants for Industrial, Commercial, and Institutional Boilers Area Sources****What are my notification, reporting, and recordkeeping requirements?**

[Additional authority for this permit condition is also derived from 25 Pa. Code § 127.35.]

**SECTION D. Source Level Requirements**

(a) The permittee shall prepare, by March 1 of each year, and submit to the Department and the USEPA upon request, a biennial compliance certification report (for boilers greater than 5.0 MMBtu/hr) or a once-every 5-year (for boilers less than 5.0 MMBtu/hr) compliance certification report for the previous calendar year(s) containing the following information:

(1) Company name and address.

(2) Statement by a responsible official, with the official's name, title, phone number, email address, and signature, certifying the truth, accuracy and completeness of the notification and a statement of whether the source has complied with all the relevant standards and other requirements of Subpart JJJJJJ. The notification must include the following certification(s) of compliance, as applicable, and signed by a responsible official:

(i) "This facility complies with the requirements in 40 CFR § 63.11223 to conduct a biennial or 5-year tune-up, as applicable, of each boiler."

(ii) For units that do not qualify for a statutory exemption as provided in section 129(g)(1) of the Clean Air Act: "No secondary materials that are solid waste were combusted in any affected unit."

(iii) "This facility complies with the requirement in 40 CFR §§ 63.11214(d) and 63.11223(g) to minimize the boiler's time spent during startup and shutdown and to conduct startups and shutdowns according to the manufacturer's recommended procedures or procedures specified for a boiler of similar design if manufacturer's recommended procedures are not available."

(b) The permittee shall submit the compliance report by March 15 if there were any instance of deviations from the applicable requirements during the reporting period, include a description of deviations, the time periods during which the deviations occurred, and the corrective actions taken.

004 [40 CFR Part 63 NESHAPS for Source Categories §40 CFR 63.11225]

Subpart JJJJJJ - National Emission Standards for Hazardous Air Pollutants for Industrial, Commercial, and Institutional Boilers Area Sources

What are my notification, reporting, and recordkeeping requirements?

[Additional authority for this permit condition is also derived from 25 Pa. Code § 127.35.]

(a) The permittee shall maintain the following records:

(1) A copy of each notification and report submitted to comply with Subpart JJJJJJ and all documentation supporting any Initial Notification or Notification of Compliance Status submitted.

(2) Documentation of conformance with the work practices (tune-up) required by 40 CFR § 63.11214 and 40 CFR § 63.11223. Records must identify each boiler, the date of tune-up, the procedures followed for tune-up, and the manufacturer's specifications to which the boiler was tuned.

(3) Records of the occurrence and duration of each malfunction of the boiler, or of the associated air pollution control and monitoring equipment.

(4) Records of actions taken during periods of malfunction to minimize emissions in accordance with the general duty to minimize emissions, including corrective actions to restore the malfunctioning boiler, air pollution control, or monitoring equipment to its normal or usual manner of operation.

(b) Records must be in a form suitable and readily available for expeditious review. The permittee shall keep each record for 5 years following the date of each recorded action. The permittee shall keep each record on-site or be accessible from a central location by computer or other means that instantly provide access at the site for at least 2 years after the date of each recorded action. The permittee may keep the records off site for the remaining 3 years.

**SECTION D. Source Level Requirements****V. REPORTING REQUIREMENTS.****# 005 [40 CFR Part 63 NESHAPS for Source Categories §40 CFR 63.11225]****Subpart JJJJJJ - National Emission Standards for Hazardous Air Pollutants for Industrial, Commercial, and Institutional Boilers Area Sources****What are my notification, reporting, and recordkeeping requirements?**

[Additional authority for this permit condition is also derived from 25 Pa. Code § 127.35.]

(a) The permittee shall submit an Initial Notification no later than January 20, 2014.

[Compliance with (a) of this condition has been met by submitting the Initial Notification to the USEPA on September 16, 2011.]

(b) The permittee shall submit a Notification of Compliance Status (NOCS) no later than July 19, 2014 (120 days after the compliance date of March 21, 2014).

(1) The NOCS must be signed by a responsible official who shall certify its accuracy and must attest to whether the source has complied with the relevant standard.

(2) The NOCS shall list the methods that were used to determine compliance.

(3) The NOCS shall list the methods that will be used for determining continuing compliance, including a description of monitoring and reporting requirements and test methods.

(4) The NOCS shall include a statement by the permittee as to whether the source has complied with the relevant standard or other requirements: "This facility complies with the requirements in 40 CFR § 63.11214 to conduct an initial tune-up of the boiler."

(5) For units that do not qualify for a statutory exemption as provided in Section 129(g)(1) of the Clean Air Act: "No secondary materials that are solid waste were combusted in any affected unit."

(6) The NOCS must be submitted electronically using the Compliance and Emissions Data Reporting Interface (CEDRI) that is accessed through EPA's Central Data Exchange (CDX) (www.epa.gov/cdx). However, if the reporting form specific to this subpart is not available in CEDRI at the time that the report is due, the written Notification of Compliance Status must be submitted to the Department and the USEPA at the appropriate address listed in 40 CFR § 63.13.

[Compliance with (b) of this condition has been met by submitting the NOCS to the USEPA on December 27, 2012.]

VI. WORK PRACTICE REQUIREMENTS.**# 006 [40 CFR Part 63 NESHAPS for Source Categories §40 CFR 63.11201]****Subpart JJJJJJ - National Emission Standards for Hazardous Air Pollutants for Industrial, Commercial, and Institutional Boilers Area Sources****What standards must I meet?**

[Additional authority for this permit condition is also derived from 25 Pa. Code § 127.35, 40 CFR § 63.11214(b), 40 CFR § 63.11223(b) and (e) and Table 2, Item No. 12.]

The permittee shall conduct a tune-up of each boiler listed in Source ID 033 once every five (5) years. Each 5-year tune-up must be conducted no more than 61 months after the previous tune-up. The permittee may delay the burner inspection and inspection of the system controlling the air-to-fuel ratio until the next scheduled unit shutdown, but you must inspect each burner and system controlling the air-to-fuel ratio at least once every 72 months.

007 [40 CFR Part 63 NESHAPS for Source Categories §40 CFR 63.11201]**Subpart JJJJJJ - National Emission Standards for Hazardous Air Pollutants for Industrial, Commercial, and Institutional Boilers Area Sources****What standards must I meet?**

[Additional authority for this permit condition is also derived from 25 Pa. Code § 127.35 and 40 CFR § 63.11214(b) and §

**SECTION D. Source Level Requirements**

63.11210(c.)

The permittee shall conduct an initial tune-up of the boiler(s) no later than March 21, 2014.

[Compliance with this condition has been met in December 2012.]

008 [40 CFR Part 63 NESHAPS for Source Categories §40 CFR 63.11205]

Subpart JJJJJJ - National Emission Standards for Hazardous Air Pollutants for Industrial, Commercial, and Institutional Boilers Area Sources

What are my general requirements for complying with this subpart?

[Additional authority for this permit condition is also derived from 25 Pa. Code § 127.35.]

At all times the permittee shall operate and maintain any affected source, including associated air pollution control equipment and monitoring equipment, in a manner consistent with safety and good air pollution control practices for minimizing emissions. The general duty to minimize emissions does not require the permittee to make any further efforts to reduce emissions if levels required by this standard have been achieved. Determination of whether such operation and maintenance procedures are being used will be based on information available to the Department and the USEPA that may include, but is not limited to, monitoring results, review of operation and maintenance procedures, review of operation and maintenance records, and inspection of the source.

009 [40 CFR Part 63 NESHAPS for Source Categories §40 CFR 63.11223]

Subpart JJJJJJ - National Emission Standards for Hazardous Air Pollutants for Industrial, Commercial, and Institutional Boilers Area Sources

How do I demonstrate continuous compliance with the work practice and management practice standards?

[Additional authority for this permit condition is also derived from 25 Pa. Code § 127.35.]

(a) The permittee shall conduct the performance tune-up as follows:

(1) While burning the type of fuel (or fuels in the case of boilers that routinely burn two types of fuels at the same time) that provided the majority of the heat input to the boiler over the 12 months prior to the tune-up.

(2) As applicable, inspect the burner, and clean or replace any components of the burner as necessary (the permittee may delay the burner inspection until the next scheduled unit shutdown, not to exceed 36 months from the previous inspection).

(3) Inspect the flame pattern, as applicable, and adjust the burner as necessary to optimize the flame pattern. The adjustment should be consistent with the manufacturer's specifications, if available.

(4) Inspect the system controlling the air-to-fuel ratio, as applicable, and ensure that it is correctly calibrated and functioning properly (the permittee may delay the inspection until the next scheduled unit shutdown, not to exceed 36 months from the previous inspection).

(5) Optimize total emissions of CO. This optimization should be consistent with the manufacturer's specifications, if available, and with any nitrogen oxide requirement to which the unit is subject.

(6) Measure the concentrations in the effluent stream of CO in parts per million, by volume, and oxygen in volume percent, before and after the adjustments are made (measurements may be either on a dry or wet basis, as long as it is the same basis before and after the adjustments are made). Measurements may be taken using a portable CO analyzer.

(b) If the unit is not operating on the required date for a tune-up, the tune-up must be conducted within 30 days of startup.

VII. ADDITIONAL REQUIREMENTS.

010 [25 Pa. Code §127.441]

Operating permit terms and conditions.

Source ID 033 contains the following boilers fired by No. 2 fuel oil:

**SECTION D. Source Level Requirements**

1-VES-002 located in the Steam Boiler Room (Boiler #2): 2.092 MMBtu/hr Cleaver Brooks Boiler, Model No. CB-100-50, installed in 1979.

2-VES-003 located in the Warehouse Boiler Room (Warehouse and Dock Heat): 1.675 MMBtu/hr York Shipley Boiler, Model No. SPHV-50-2-93948. installed in 1986.

**SECTION D. Source Level Requirements**

Source ID: 100

Source Name: DRY BUILDING 1 - PLASTIC MASTERBATCH CENTER

Source Capacity/Throughput:

N/A

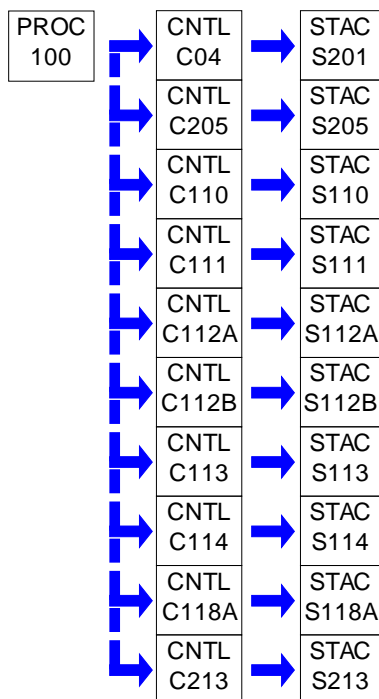
**I. RESTRICTIONS.****Emission Restriction(s).****# 001 [25 Pa. Code §127.441]****Operating permit terms and conditions.**

[Additional authority for this permit condition is also derived from 25 Pa. Code § 127.1]

No person may permit the emission into the outdoor atmosphere of particulate matter from a process in a manner that the concentration of filterable particulate matter in the effluent gas exceeds 0.02 grain per dry standard cubic foot, according to 25 Pa. Code § 127.1.

[The method of compliance for this condition is the proper operation and maintenance of each dust collector associated with process units operating as part of the Plastic Masterbatch Center.]

002 [25 Pa. Code §127.441]**Operating permit terms and conditions.**

The permittee shall limit the aggregate VOC emissions from all sources operating as part of Plastic Masterbatch Center (Dry Building) to 6.75 tons per year, based on a 12-month rolling sum.

II. TESTING REQUIREMENTS.

No additional testing requirements exist except as provided in other sections of this permit including Section B (State Only General Requirements).

**SECTION D. Source Level Requirements****III. MONITORING REQUIREMENTS.****# 003 [25 Pa. Code §127.441]****Operating permit terms and conditions.**

The permittee shall monitor the following parameters for all units listed in VII. Additional Requirements for Source ID 100 to determine actual emissions for Source ID 100:

- (a) weight of material processed (in pounds of material) per batch.
- (b) type of chemicals to identify regulated pollutants, i.e. VOC, HAP, and PM, per batch.
- (c) number of batches processed per month.

004 [25 Pa. Code §127.441]**Operating permit terms and conditions.**

The permittee shall base aggregate VOC, HAP, and PM emission calculations on material throughput (in pounds) and regulated pollutant content (% by weight), i.e. VOC, HAP, PM, from Safety Data Sheets (SDS), or other method approved in writing by DEP, for all sources operating as part of the Plastic Masterbatch Center.

IV. RECORDKEEPING REQUIREMENTS.**# 005 [25 Pa. Code §127.441]****Operating permit terms and conditions.**

(a) The permittee shall maintain records of the following parameters for all units listed in VII. Additional Requirements for Source ID 100 and operating as part of the Plastic Masterbatch Center to determine actual emissions for Source ID 100:

- (1) weight of material processed (in pounds of material) per batch.
- (2) type of chemicals to identify regulated pollutants per batch.
- (3) number of batches processed per month.

(b) The permittee shall maintain Safety Data Sheets (SDS) for all material processed in the Plastic Masterbatch Center, indicating regulated pollutant content (% by weight), i.e. VOC, HAP, PM, as applicable, or other method approved in writing by DEP.

(c) The permittee shall maintain monthly records of aggregate VOC, HAP, and PM emissions from all sources operating as part of the Plastic Masterbatch Center, including 12-month rolling sums.

V. REPORTING REQUIREMENTS.

No additional reporting requirements exist except as provided in other sections of this permit including Section B (State Only General Requirements).

VI. WORK PRACTICE REQUIREMENTS.**# 006 [25 Pa. Code §127.441]****Operating permit terms and conditions.**

The permittee shall operate and maintain the units contained in Source ID 100 and operating as part of the Plastic Masterbatch Center in accordance with good air pollution control practices.

VII. ADDITIONAL REQUIREMENTS.**# 007 [25 Pa. Code §127.441]****Operating permit terms and conditions.**

Source ID 100 - Plastic Masterbatch Center/Dry Building 1 - contains the following units:

Tote Loading,
Tote Tumblers 1 & 2,
Mixer B1,
Mixer B2,
Roll Mill B 50",

**SECTION D. Source Level Requirements**

Extruder E5 36 mm,
Extruder E7 53 mm,
Extruder E9 40 mm,
Extruder E11,
Lab Hoods,
Roll Mill G (60"),
Chipper D2 (20 HP),
Chipper D3 (30 HP),
Mixer D2 (30 cu ft.),
Pulverizer D1 (20 HP),
Pulverizer D2 (30 HP),
Roll Mill D2 (60"),
Continuous Line C1 Dry Building (500 lbs),
Continuous Line C2 Dry Building 150 HP,
Continuous Line C3 (500 lbs),
Continuous Line C5 (60 lbs),
Pulverizer C5 (40 HP),
Blender B30 (Premix Room) 30 cu ft,
Premix Blender H10 (Premix Room) 100 cu ft,
Henschel H11 High Intensity Mixer (Premix Room) 1200 liter,
Henschel H12 High Intensity Mixer (Premix Room) 600 liter,
Mixer B60 Mixer (Premix Room) 60 cu ft,
Mixer B90 Mixer (Premix Room) 90 cu ft,
Extruder E4 Extruder (Extruder Room) 53 mm,
Extruder E6 Extruder (Extruder Room) 53 mm,
Extruder E8 Extruder (Extruder Room) 50 mm,
Roll Mill E 60",
F Blender 30 cu ft,
Henschel H1 High Intensity Mixer 500 liter,
Henschel H2 High Intensity Mixer 500 liter,
Henschel H5 High Intensity Mixer Dry 500 liter,
Extruder CM1 (FCM Extruder Room) 60 HP,
Extruder CM2 (FCM Extruder Room) 60 HP,
Extruder F4 (FCM Extruder Room) 150 HP,
Continuous Line C4 80 lbs,
C4 Pulverizer,
Extruder E12,
High Intensity Mixer H8,
High Intensity Mixer H9,
Extruder E10,
Extruder 14 E14,
Extruder 15 E15,
Roll Mill C,
Extruder E16
Extruder E17 (with mixer and loading)
Extruder E18 (with mixer and loading)
Extruder E19 (with mixer and loading)
Continuous C6 Process Line (Source ID 213) mixing, extrusion, and pulverizing.

**SECTION D. Source Level Requirements**

Source ID: 126

Source Name: TWO (2) EMERGENCY GENERATORS

Source Capacity/Throughput:

N/A

#2 Oil

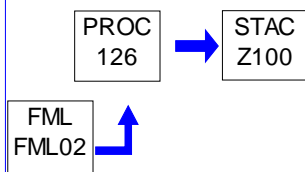
**I. RESTRICTIONS.****Emission Restriction(s).****# 001 [25 Pa. Code §123.13]****Processes**

The permittee shall ensure that emission into the outdoor atmosphere of particulate matter from the emergency generator occurs in such a manner that the concentration of particulate matter in the effluent gas does not exceed 0.04 gr/dscf, according to 25 Pa. Code § 123.13(c)(1)(i).

[The method of compliance for this permit condition is using proper fuels as approved herein.]

002 [25 Pa. Code §123.21]**General**

No person may permit the emission into the outdoor atmosphere of sulfur oxides from a source in a manner that the concentration of the sulfur oxides, expressed as SO₂, in the effluent gas exceeds 500 parts per million, by volume, dry basis.

[Compliance with this condition may be demonstrated by verifying that the sulfur content of the diesel fuel oil is equal to or less than 0.05% by weight, as derived from 25 Pa. Code § 123.22(e)(2)(i).]

003 [25 Pa. Code §127.441]**Operating permit terms and conditions.**

The permittee shall limit the aggregate NO_x emissions from all exempt engines on site to less than 100 lbs/hr, 1000 lbs/day, 2.75 tons per ozone season and 6.6 tons per year on a 12-month rolling basis.

Fuel Restriction(s).**# 004 [25 Pa. Code §127.441]****Operating permit terms and conditions.**

The permittee shall burn No. 2 fuel oil only in the emergency generators.

Operation Hours Restriction(s).**# 005 [40 CFR Part 63 NESHAPS for Source Categories §40 CFR 63.6640]****Subpart ZZZZ - National Emissions Standards for Hazardous Air Pollutants for Stationary Reciprocating Internal Combustion Engines****How do I demonstrate continuous compliance with the emission limitations, operating limitations, and other requirements?**

[Additional authority for this permit condition is also derived from 25 Pa. Code § 127.35]

The permittee shall limit the hours of operation for this emergency generator as follows, according to 40 CFR § 63.6640(f):

(a) No more than one hundred (100) hours per year for maintenance checks and readiness testing as required by the manufacturer, insurance company, or government agency; and

(b) No more than fifty (50) hours in non-emergency situations, but these fifty must be counted toward the 100 hours for maintenance and readiness testing. These 50 hours cannot be used for peak shaving or to generate income by supplying

**SECTION D. Source Level Requirements**

power as part of a financial arrangement with another entity.

(c) There is no time limit while operating the emergency stationary RICE in emergency situations.

II. TESTING REQUIREMENTS.

006 [25 Pa. Code §139.16]

Sulfur in fuel oil.

(a) The following are applicable to tests for the analysis of commercial fuel oil:

(1) The fuel oil sample for chemical analysis shall be collected in a manner that provides a representative sample. Upon the request of a Department official, the person responsible for the operation of the source shall collect the sample employing the procedures and equipment specified in 25 Pa. Code § 139.4(10) (relating to references).

(2) Test methods and procedures for the determination of viscosity shall be that specified in 25 Pa. Code § 139.4(11) (relating to references). The viscosity shall be determined at 100°F.

(3) Tests methods and procedures for the determination of sulfur shall be those specified in 25 Pa. Code § 139.4(12)--(15).

(4) Results shall be reported in accordance with the units specified in 25 Pa. Code § 123.22 (relating to combustion units).

(b) The testing requirements in subpart (a) above, shall be waived in the event that a delivery receipt from the supplier, showing the percentage sulfur in the fuel, is obtained each time a fuel oil delivery is made.

III. MONITORING REQUIREMENTS.

No additional monitoring requirements exist except as provided in other sections of this permit including Section B (State Only General Requirements).

IV. RECORDKEEPING REQUIREMENTS.

007 [25 Pa. Code §127.441]

Operating permit terms and conditions.

The permittee shall maintain monthly records of the aggregate NOx emissions from all exempt engines on site including pounds per hour, pounds per day, ozone season (i.e., the period from May 1 through September 30 of each year) sums, and 12-month rolling sums to demonstrate compliance with the NOx emission limits applicable to this source.

008 [40 CFR Part 63 NESHAPS for Source Categories §40 CFR 63.6655]

Subpart ZZZZ - National Emissions Standards for Hazardous Air Pollutants for Stationary Reciprocating Internal Combustion Engines**What records must I keep?**

[Additional authority for this permit condition is also derived from 25 Pa. Code § 127.35]

The following recordkeeping requirements apply to the engine, according to 40 CFR § 63.6655(f)(1):

(a) The permittee shall keep records of the hours of operation of the engine that is recorded through a non-resettable hour meter.

(b) The permittee shall document how many hours are spent for emergency operation (12-month rolling), including what classified the operation as emergency and how many hours are spent for non-emergency operation (12-month rolling).

009 [40 CFR Part 63 NESHAPS for Source Categories §40 CFR 63.6655]

Subpart ZZZZ - National Emissions Standards for Hazardous Air Pollutants for Stationary Reciprocating Internal Combustion Engines

**SECTION D. Source Level Requirements****What records must I keep?**

Additional authority for this permit condition is also derived from 25 Pa. Code § 127.35]

The permittee shall keep records of the maintenance conducted on the emergency generator in order to demonstrate that the source is operated and maintained according to a maintenance plan, according to 40 CFR § 63.6655(e)(2).

010 [40 CFR Part 63 NESHAPS for Source Categories §40 CFR 63.6660]**Subpart ZZZZ - National Emissions Standards for Hazardous Air Pollutants for Stationary Reciprocating Internal Combustion Engines****In what form and how long must I keep my records?**

[Additional authority for this permit condition is also derived from 25 Pa. Code § 127.35.]

(a) The permittee shall maintain records in a form suitable and readily available for expeditious review according to 40 CFR § 63.10(b)(1).

(b) As specified in 40 CFR § 63.10(b)(1), the permittee shall keep each record for 5 years following the date of each occurrence, measurement, maintenance, corrective action, report, or record.

(c) The permittee shall must keep each record readily accessible in hard copy or electronic form for at least 5 years after the date of each occurrence, measurement, maintenance, corrective action, report, or record, according to 40 CFR § 63.10(b)(1).

V. REPORTING REQUIREMENTS.

No additional reporting requirements exist except as provided in other sections of this permit including Section B (State Only General Requirements).

VI. WORK PRACTICE REQUIREMENTS.**# 011 [40 CFR Part 63 NESHAPS for Source Categories §40 CFR 63.6603]****Subpart ZZZZ - National Emissions Standards for Hazardous Air Pollutants for Stationary Reciprocating Internal Combustion Engines****What emission limitations, operating limitations, and other requirements must I meet if I own or operate an existing stationary RICE located at an area source of HAP emissions?**

[Additional authority for this permit condition is also derived from 25 Pa. Code § 127.35]

The permittee shall perform the following work practice standards on this emergency generator, according to 40 CFR § 63.6603(a) and Table 2d (Item 4) of Subpart ZZZZ:

- (a) Change oil and filter every 500 hours of operation or annually, whichever comes first,
- (b) Inspect air cleaner every 1,000 hours of operation or annually, whichever comes first, and replace as necessary; and
- (c) Inspect all hoses and belts every 500 hours of operation or annually, whichever comes first, and replace as necessary.

The permittee has the option to utilize an oil analysis program as described in 40 CFR § 63.6625(j) in order to extend the specified oil change requirement in (a) above.

012 [40 CFR Part 63 NESHAPS for Source Categories §40 CFR 63.6605]**Subpart ZZZZ - National Emissions Standards for Hazardous Air Pollutants for Stationary Reciprocating Internal Combustion Engines****What are my general requirements for complying with this subpart?**

(a) The permittee shall be in compliance with the applicable requirements of 40 CFR Part 63 Subpart ZZZZ at all times.

(b) At all times the permittee shall operate and maintain the affected source, including associated air pollution control equipment and monitoring equipment, in a manner consistent with safety and good air pollution control practices for minimizing emissions. The general duty to minimize emissions does not require the permittee to make any further efforts to reduce emissions if levels required by this standard have been achieved. Determination of whether such operation and

**SECTION D. Source Level Requirements**

maintenance procedures are being used will be based on information available to the Department which may include, but is not limited to, monitoring results, review of operation and maintenance procedures, review of operation and maintenance records, and inspection of the source.

013 [40 CFR Part 63 NESHAPS for Source Categories §40 CFR 63.6625]

Subpart ZZZZ - National Emissions Standards for Hazardous Air Pollutants for Stationary Reciprocating Internal Combustion Engines

What are my monitoring, installation, operation, and maintenance requirements?

[Additional authority for this permit condition is also derived from 25 Pa. Code § 127.35]

The permittee shall operate and maintain the stationary RICE according to the manufacturer's emission-related written instructions or facility-developed maintenance plan which must provide to the extent practicable for the maintenance and operation of the engine in a manner consistent with good air pollution control practice for minimizing emissions, according to 40 CFR § 63.6625(e)(3).

VII. ADDITIONAL REQUIREMENTS.

014 [25 Pa. Code §127.441]

Operating permit terms and conditions.

Source ID 126 contains two (2) exempt emergency generators, each powered by a stationary internal combustion engine as follows:

- (a) Dry Building Emergency Generator – powered by a diesel fuel oil Caterpillar engine rated at 449 hp and 300 kW (20.9 gallons per hour), Model Year 2022, Model No. 3406, installed in 2003.
- (b) Wet Building Emergency Generator – powered by a diesel fuel oil Detroit engine rated at 400 hp and 276 kW (20.9 gallons per hour), installed in 2000.

**SECTION D. Source Level Requirements**

Source ID: 200

Source Name: WET BUILDING 2 - LIQUID DISPERSION CENTER

Source Capacity/Throughput:

N/A

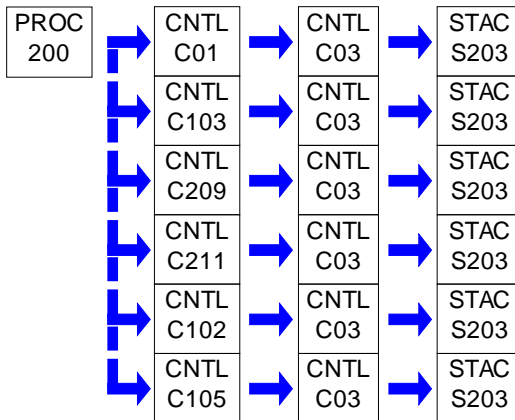

This source occurs in alternate operation ZERO VOC MATERIAL

I. RESTRICTIONS.**Emission Restriction(s).****# 001 [25 Pa. Code §127.441]****Operating permit terms and conditions.**

The permittee shall limit the aggregate post-control VOC emissions from all sources operating as part of the Liquid Dispersion Center (Wet Building) to 13.9 tons per year, based on a 12-month rolling sum. The post-control VOC emission limit includes emissions from solvent-based clean-up activities performed as part of the Liquid Dispersion Center.

002 [25 Pa. Code §127.441]**Operating permit terms and conditions.**

[Additional authority for this permit condition is also derived from 25 Pa. Code § 127.1]

No person may permit the emission into the outdoor atmosphere of particulate matter from a process in a manner that the concentration of filterable particulate matter in the effluent gas exceeds 0.02 grain per dry standard cubic foot, according to 25 Pa. Code § 127.1.

[The method of compliance for this condition is the proper operation and maintenance of each dust collector associated with process units operating as part of the Liquid Dispersion Center.]

II. TESTING REQUIREMENTS.

No additional testing requirements exist except as provided in other sections of this permit including Section B (State Only General Requirements).

III. MONITORING REQUIREMENTS.**# 003 [25 Pa. Code §127.441]****Operating permit terms and conditions.**

(a) The permittee shall base post-control VOC and HAP emission calculations on information obtained from the mass-balance tracking system in place, the number of batches per month for all sources and equipment ducted to the RTO, and the overall control device efficiency (based on the most recent stack test results) of the RTO.

(b) The permittee shall base post-control particulate matter calculations, including particulate HAP emissions, on information obtained from the mass-balance tracking system in place, the number of batches per month for all sources and

**SECTION D. Source Level Requirements**

equipment ducted to the control devices, emission factor (i.e. AP-42, or other method as approved by the Department), and the control device efficiency.

(c) The permittee shall base clean-up activity emission calculations on the amount of solvent lost during cleaning of process equipment per month.

004 [25 Pa. Code §127.441]**Operating permit terms and conditions.**

The permittee shall monitor the following parameters for all units operating as part of the Liquid Dispersion Center located in the Wet Building:

- (a) material processed (pounds of material per batch),
- (b) product yielded (pounds of product per batch),
- (c) number of batches per month,
- (d) amount of solvent lost during clean-up per month.

IV. RECORDKEEPING REQUIREMENTS.**# 005 [25 Pa. Code §127.441]****Operating permit terms and conditions.**

(a) The permittee shall maintain records of the following for each unit operating as part of the Liquid Dispersion Center located in the Wet Building:

- (1) material processed (pounds of material per batch),
- (2) product yielded (pounds of product per batch),
- (3) number of batches per month,
- (4) total losses, per batch (difference between chemicals processed and product yielded).

(b) The permittee shall maintain Safety Data Sheets (SDS) for all material processed in the Liquid Dispersion Center, indicating regulated pollutant content (% by weight), i.e. VOC, HAP, PM, as applicable, or other method approved in writing by DEP.

006 [25 Pa. Code §127.441]**Operating permit terms and conditions.**

The permittee shall maintain monthly records of total post-control VOC emissions from all units operating as part of the Liquid Dispersion Center and located in the Wet Building, including 12-month rolling sums.

V. REPORTING REQUIREMENTS.

No additional reporting requirements exist except as provided in other sections of this permit including Section B (State Only General Requirements).

VI. WORK PRACTICE REQUIREMENTS.**# 007 [25 Pa. Code §127.441]****Operating permit terms and conditions.**

The permittee shall ensure each cowles dissolver listed in this Source ID is equipped with a cover, which completely covers the vessel, except for an opening no larger than necessary to allow for safe clearance of any mixer shaft. Such a cover shall extend at least ½ inch beyond the outer rim of the opening or be attached at the rim.

008 [25 Pa. Code §127.441]**Operating permit terms and conditions.**

The permittee shall operate and maintain the units contained in Source ID 200 and operating as part of the Liquid Dispersion Center in accordance with good air pollution control practices.

**SECTION D. Source Level Requirements****# 009 [25 Pa. Code §127.441]****Operating permit terms and conditions.**

The permittee shall maintain the permanent total enclosure for this source in the same configuration as it is tested, unless otherwise approved by the Department.

010 [25 Pa. Code §127.441]**Operating permit terms and conditions.**

(a) The permittee shall direct VOC emissions from all units operating as part of the Liquid Dispersion Center and located in the Wet Building to the Regenerative Thermal Oxidizer (C03).

(b) The permittee shall not operate any equipment listed in this Source ID if the 3-hour average temperature of the RTO drops below the 3-hour average temperature achieved during the most recent compliant source test approved by DEP.

(c) The permittee shall not operate any equipment listed in this Source ID if the permanent total enclosure is not maintained in the same configuration as it was tested.

011 [25 Pa. Code §127.441]**Operating permit terms and conditions.**

The permittee shall perform all clean up operations for all process units operating as part of the Liquid Dispersion Center located in the Wet Building within the total enclosure while vented to the RTO.

VII. ADDITIONAL REQUIREMENTS.**# 012 [25 Pa. Code §127.441]****Operating permit terms and conditions.**

Source ID 200 - Liquid Dispersion Center located in the Wet Building consists of the following process units:

Source ID 101 (Wing C, Wing I, Wing F):

BMC1 Basket Mill C Wing 60 HP 1;
 CMC1 High Speed Dispenser C Wing 20 HP 1;
 CMC2 High Speed Dispenser C Wing 10 HP 2;
 CMC3 High Speed Dispenser C Wing 10 HP 3;
 FCC1 Filter Cowles C Wing 600 gal 1;
 HMMC1 (130) Horizontal Media Mill C Wing 20 liters 1;
 HMMC10 Horizontal Media Mill C Wing 60 liters 10;
 HMMC11 Horizontal Media Mill C Wing 8 liters 11;
 HMMC12 Horizontal Media Mill C Wing 20 liters 12;
 HMMC19 Horizontal Media Mill C Wing 10 liters 19;
 HMMC20 Horizontal Media Mill C Wing;
 Cowles Mixer and Netzsch Neos Mill C Wing (NEOS20);
 HMMC3 Horizontal Media Mill C Wing 33 liters 3;
 HMMC5 Horizontal Media Mill C Wing 45 liters 5;
 HMMC6 Horizontal Media Mill C Wing 60 liters 6;
 Cowles Mixer and Buhler Invicta 3 Mill C Wing (MMI3);
 HMMC9 Horizontal Media Mill C Wing 25 liters 9;
 HMMCP1 Horizontal Media Mill Pilot C Wing 1.5 liters 1;
 HMMCP2 Horizontal Media Mill Pilot C Wing 2 liters 2;
 HMMCP3 Horizontal Media Mill Pilot C Wing 4 liters 3;
 HMMCP4 Horizontal Media Mill Pilot C Wing 4 liters 4;
 HSDC14 High Speed Dispenser C Wing 1500 gal 14;
 HSDCP1 High Speed Dispenser Pilot C Wing 1.5 HP 1;
 HSDCP3 High Speed Dispenser Pilot C Wing 5 HP 3;
 HSDF1 High Speed Dispenser F Wing 450 gal 1;
 Pilot Air Mixer Pilot Air Mixer C Wing 1 HP;
 Pot Washer C Wing;
 Solvent Recovery Still Solvent Recovery Still I Wing 500 gal;

**SECTION D. Source Level Requirements**

VMMC14 Vertical Media Mill C Wing 15 liters 14;
VMMC15 Vertical Media Mill C Wing 15 liters 15;
VMMC17 Vertical Media Mill C Wing 12.5 liters 17;
VMMC8 Vertical Media Mill C Wing 15 liters 8;
CFFC1 Centrifugal Filter C Wing 9 liters;
1 Wash Sink I Wing;
3 Wash Sinks C Wing.

Source ID 102 (Wing C):

HSDC1 High Speed Dispenser C Wing 150 gal 1;
HSDC11 High Speed Dispenser C Wing 500 gal 11;
HSDC13 High Speed Dispenser C Wing 500 gal 13;
HSDC3 High Speed Dispenser C Wing 650 gal 3;
HSDC5 High Speed Dispenser C Wing 200 gal 5;
HSDC7 High Speed Dispenser C Wing 500 gal 7;
HSDC9 High Speed Dispenser C Wing 300 gal 9;
TMC1 Turbo Mill C Wing 500 gal 1;
Cleaning.

Source ID 103 (Wing C):

HSDC10 High Speed Dispenser C Wing 500 gal 10;
HSDC12 High Speed Dispenser C Wing 300 gal 12;
HSDC2 High Speed Dispenser C Wing 500 gal 2;
HSDC4 High Speed Dispenser C Wing 500 gal 4;
HSDC6 High Speed Dispenser C Wing 500 gal 6;
HSDC8 High Speed Dispenser C Wing 150 gal 8;
RS1 Rotor Stator C Wing 300 gal 1;
BM2 Turbo Mill C Wing 500 gal 2;
Cleaning.

Source ID 105 (Wing E):

SBME1 Steel Ball Mill (Enclosed Mixing Vessel) E Wing 650 gal;
BME1 Basket Mill Wing E;
Wash Sinks, and Cleaning.

Source ID 106 (Wing F):

RMF2 Roll Mill F Wing 60" 2;
BPF5 Baker Perkins (Horizontal Mixer) F Wing 150 gal 5;
BPF6 Baker Perkins (Horizontal Mixer) F Wing 150 gal 6;
BPF1 Baker Perkins (Horizontal Mixer) F Wing 150 gal 1;
RMF1 Roll Mill F Wing 60" 1;
BPF2 Baker Perkins (Horizontal Mixer) F Wing 150 gal;
BPF3 Baker Perkins (Horizontal Mixer) F Wing 25 gal;
BPF4 Baker Perkins (Horizontal Mixer) F Wing 75 gal;
Wash Sinks and Cleaning.

Source ID 108 (Wing G and Wing H):

Retrofit 60" Mill (previously in storage)
RMG1 Roll Mill G Wing 60" 1;
RMG2 Roll Mill G Wing 50" 2;
RMH1 Roll Mill H Wing 42" 1;
RMH2 Roll Mill H Wing 42" 2;
RMH3 Roll Mill H Wing 42" 3;
RMH4 Roll Mill H Wing 42" 4;
CHIPG1 Chipper G Wing 30 HP 1;
CHIPG2 Chipper G Wing 30 HP 2;

**SECTION D. Source Level Requirements**

PMG1 Premixer G Wing 100 gal 1;
PMG2 Premixer G Wing 100 gal 2;
PMH2 Premixer H Wing 100 gal 2;
PMH3A Premixer H Wing 100 gal 3A;
PMH3B Premixer H Wing 100 gal 3B;
PMH4 Premixer H Wing 100 gal 4;
Wash Sinks and Cleaning.

Source ID 123: Wet Building Pre-Mix Dispenser PMDD4

Source ID 207: Wet Building Baker Perkins PBG3 Mixer 300 Gal, G Wing.

Source ID 208: Wet Building Baker Perkins PBG4 Mixer 300 Gal.

Source ID 209: Wet Building Pre-Mix Dispenser PMDD1, and associated equipment.

Source ID 210: Wet Building Pre-Mix Dispenser PMDD2, and associated equipment.

Source ID 211: Wet Building Pre-Mix Dispenser PMDD3, and associated equipment.

HSD E1
HSD E2
CT E1
CT E2.

**SECTION D. Source Level Requirements**

Source ID: 204

Source Name: MAINTENANCE AREA REMOTE RESERVOIR PARTS WASHER

Source Capacity/Throughput:

I. RESTRICTIONS.

No additional requirements exist except as provided in other sections of this permit including Section B (State Only General Requirements).

II. TESTING REQUIREMENTS.

No additional testing requirements exist except as provided in other sections of this permit including Section B (State Only General Requirements).

III. MONITORING REQUIREMENTS.

No additional monitoring requirements exist except as provided in other sections of this permit including Section B (State Only General Requirements).

IV. RECORDKEEPING REQUIREMENTS.**# 001 [25 Pa. Code §129.63]****Degreasing operations**

The permittee shall perform the following recordkeeping for each parts washer:

(a) The permittee shall maintain records and provide to the Department, on request, the information specified below, pursuant to 25 Pa. Code § 129.63(a)(6):

- (1) The name and address of the solvent supplier, as applicable.
- (2) The type of solvent including the product or vendor identification number, as applicable.
- (3) The vapor pressure of the solvent measured in mm Hg at 20°C (68°F).

(b) An invoice, bill of sale, certificate that corresponds to a number of sales, Safety Data Sheet (SDS), or other appropriate documentation acceptable to the Department may be used to comply with this condition.

V. REPORTING REQUIREMENTS.

No additional reporting requirements exist except as provided in other sections of this permit including Section B (State Only General Requirements).

VI. WORK PRACTICE REQUIREMENTS.**# 002 [25 Pa. Code §129.63]****Degreasing operations**

The permittee should perform the following discretionary good operating practices for all parts washers, pursuant to 25 Pa. Code § 129.63(a)(2)(i)(A)-(C):

- (a) Cleaned parts should be drained at least 15 seconds or until dripping ceases, whichever is longer. Parts having cavities or blind holes shall be tipped or rotated while the part is draining. During the draining, tipping or rotating, the parts should be positioned so that solvent drains directly back to the cold cleaning machine.
- (b) When a pump-agitated solvent bath is used, the agitator should be operated to produce a rolling motion of the solvent with no observable splashing of the solvent against the tank walls or the parts being cleaned.
- (c) Work area fans should be located and positioned so that they do not blow across the opening of the degreaser unit.

003 [25 Pa. Code §129.63]**Degreasing operations**

A person may not use, sell or offer for sale for use in a cold cleaning machine any solvent with a vapor pressure of 1.0

**SECTION D. Source Level Requirements**

millimeter of mercury (mm Hg) or greater and containing greater than 5% VOC by weight, measured at 20°C (68°F) containing VOCs, pursuant to 25 Pa. Code § 129.63(a)(4),

004 [25 Pa. Code §129.63]**Degreasing operations**

The permittee shall operate the cold cleaning machines in accordance with the following procedures, pursuant to 25 Pa. Code § 129.63(a)(3):

- (a) Waste solvent shall be collected and stored in closed containers. The closed containers may contain a device that allows pressure relief, but does not allow liquid solvent to drain from the container.
- (b) Flushing of parts using a flexible hose or other flushing device shall be performed only within the cold cleaning machine. The solvent spray shall be a solid fluid stream, not an atomized or shower spray.
- (c) Sponges, fabric, wood, leather, paper products and other absorbent materials may not be cleaned in the cold cleaning machine.
- (d) Air agitated solvent baths may not be used.
- (e) Spills during solvent transfer and use of the cold cleaning machine shall be cleaned up immediately.

005 [25 Pa. Code §129.63]**Degreasing operations**

The permittee shall perform the following work practice standards for each parts washer:

- (a) The remote reservoir cold cleaning machine shall have a permanent, conspicuous label summarizing the operating requirements contained in this permit for this source, pursuant to 25 Pa. Code § 129.63(a)(2)(i).
- (b) The remote reservoir cold cleaning machine shall be equipped with a cover that shall be closed at all times except during cleaning of parts or the addition or removal of solvent. For remote reservoir cold cleaning machines which drain directly into the solvent storage reservoir, a perforated drain with a diameter of not more than 6 inches shall constitute an acceptable cover. Pursuant to 25 Pa. Code § 129.63(a)(2)(ii).

VII. ADDITIONAL REQUIREMENTS.**# 006 [25 Pa. Code §127.441]****Operating permit terms and conditions.**

Source ID 204 contains one (1) remote reservoir unit located in the Maintenance Area.

**SECTION D. Source Level Requirements**

Source ID: 214

Source Name: BUILDING 2 PARTS WASHERS

Source Capacity/Throughput:

I. RESTRICTIONS.

No additional requirements exist except as provided in other sections of this permit including Section B (State Only General Requirements).

II. TESTING REQUIREMENTS.

No additional testing requirements exist except as provided in other sections of this permit including Section B (State Only General Requirements).

III. MONITORING REQUIREMENTS.

No additional monitoring requirements exist except as provided in other sections of this permit including Section B (State Only General Requirements).

IV. RECORDKEEPING REQUIREMENTS.**# 001 [25 Pa. Code §127.441]****Operating permit terms and conditions.**

[Additional authority for this permit condition is also derived from 25 Pa. Code § 129.51(a)(5).]

(a) The permittee shall keep records of the most recent source test report, indicating the RTO (C03) control efficiency achieved during testing.

(b) The permittee shall keep records of the most recent capture efficiency test results, demonstrating the parts washers listed in Source ID 214 are routed to the RTO (C03).

V. REPORTING REQUIREMENTS.

No additional reporting requirements exist except as provided in other sections of this permit including Section B (State Only General Requirements).

VI. WORK PRACTICE REQUIREMENTS.**# 002 [25 Pa. Code §127.441]****Operating permit terms and conditions.**

[Additional authority for this permit condition is also derived from 25 Pa. Code § 129.51.]

The permittee shall reduce VOC emissions from the parts washers listed in Source ID 214 by routing emissions to the Regenerative Thermal Oxidizer (C03) when using organic-based solvents.

[The use of the RTO to control VOC emissions from the parts washers located in Building 2 meets the equivalency requirements under 25 Pa. Code §129.51(a) as an alternative compliance method for 25 Pa. Code § 129.63.]

[Compliance with this permit condition assures compliance with the requirements of 25 Pa. Code § 129.63 via equivalency under 25 Pa. Code § 129.51.]

003 [25 Pa. Code §129.63]**Degreasing operations**

The permittee shall operate the cold cleaning machines in accordance with the following procedures, pursuant to 25 Pa. Code § 129.63(a)(3)(i)-(v):

(a) Waste solvent shall be collected and stored in closed containers. The closed containers may contain a device that allows pressure relief, but does not allow liquid solvent to drain from the container.

**SECTION D. Source Level Requirements**

(b) Flushing of parts using a flexible hose or other flushing device shall be performed only within the cold cleaning machine. The solvent spray shall be a solid fluid stream, not an atomized or shower spray.

(c) Sponges, fabric, wood, leather, paper products and other absorbent materials may not be cleaned in the cold cleaning machine.

(d) Air agitated solvent baths may not be used.

(e) Spills during solvent transfer and use of the cold cleaning machine shall be cleaned up immediately.

VII. ADDITIONAL REQUIREMENTS.

004 [25 Pa. Code §127.441]

Operating permit terms and conditions.

Source ID 214 consists of nine (9) immersion cold cleaning machines located in Building 2.

**SECTION D. Source Level Requirements**

Source ID: C01

Source Name: DUST COLLECTOR, WET BUILDING, LARGE PRE-OXY

Source Capacity/Throughput:

N/A

Conditions for this source occur in the following groups: GROUP 2
GROUP 3

I. RESTRICTIONS.**Emission Restriction(s).****# 001 [25 Pa. Code §127.441]****Operating permit terms and conditions.**

The permittee shall limit post-control PM emissions from this dust collector to 8.1 tons per year, based on 12-month rolling sum.

[The PM emission limit of 8.1 tpy is the post-control sum of particulate matter emissions from all sources vented to this dust collector.]

II. TESTING REQUIREMENTS.

No additional testing requirements exist except as provided in other sections of this permit including Section B (State Only General Requirements) and/or Section E (Source Group Restrictions).

III. MONITORING REQUIREMENTS.

No additional monitoring requirements exist except as provided in other sections of this permit including Section B (State Only General Requirements) and/or Section E (Source Group Restrictions).

IV. RECORDKEEPING REQUIREMENTS.

No additional record keeping requirements exist except as provided in other sections of this permit including Section B (State Only General Requirements) and/or Section E (Source Group Restrictions).

V. REPORTING REQUIREMENTS.

No additional reporting requirements exist except as provided in other sections of this permit including Section B (State Only General Requirements) and/or Section E (Source Group Restrictions).

VI. WORK PRACTICE REQUIREMENTS.

No additional work practice requirements exist except as provided in other sections of this permit including Section B (State Only General Requirements) and/or Section E (Source Group Restrictions).

VII. ADDITIONAL REQUIREMENTS.**# 002 [25 Pa. Code §127.441]****Operating permit terms and conditions.**

The following units located in the Wet Building are ducted to this dust collector:

Source ID 108:

RMG1 Roll Mill G Wing 60" 1;

RMG2 Roll Mill G Wing 50" 2;

RMH1 Roll Mill H Wing 42" 1;

RMH2 Roll Mill H Wing 42" 2;

RMH3 Roll Mill H Wing 42" 3;

**SECTION D. Source Level Requirements**

RMH4 Roll Mill H Wing 42" 4;
CHIPG1 Chipper G Wing 30 HP 1;
CHIPG2 Chipper G Wing 30 HP 2;
PMG1 Premixer G Wing 100 gal 1;
PMG2 Premixer G Wing 100 gal 2;
PMH2 Premixer H Wing 100 gal 2;
PMH3A Premixer H Wing 100 gal 3A;
PMH3B Premixer H Wing 100 gal 3B;
PMH4 Premixer H Wing 100 gal 4;
Wash Sinks and Cleaning.

Source ID 207: Wet Building BG/B2 Baker Perkins BPG3 Horizontal Mixer 300 Gal G Wing.

Source ID 208: Wet Building B/BG2 Baker Perkins BPG4 Horizontal Mixer 300 Gal.

**SECTION D. Source Level Requirements**

Source ID: C03

Source Name: REGENERATIVE THERMAL OXIDIZER

Source Capacity/Throughput:

N/A

I. RESTRICTIONS.**Control Device Efficiency Restriction(s).****# 001 [25 Pa. Code §127.441]****Operating permit terms and conditions.**

(a) The permittee shall maintain a control equipment capture efficiency of 100% for all sources ducted to the RTO.

(b) The permittee shall maintain a minimum overall VOC control efficiency of 96% for the Regenerative Thermal Oxidizer (RTO) (Source ID C03) or limit post-control VOC emissions to 20 ppm_{dv}, as methane.

[Overall VOC control efficiency will equate to mass destruction of VOC due to permanent total enclosure, or 100% capture efficiency. Mass destruction * capture efficiency = overall control efficiency.]

[Additional authority for this permit condition is also derived from 25 Pa. Code § 129.51(a)(1)-(6), regarding Source ID 214.]

II. TESTING REQUIREMENTS.**# 002 [25 Pa. Code §127.441]****Operating permit terms and conditions.**

(a) The permittee shall perform a stack test using the Department-approved procedures, once every five (5) years, where five calendar years is defined as beginning with the calendar year the latest stack test was performed and ending on December 31, five years later. Performance tests shall be conducted while the sources are operating at maximum routine operating conditions or under such other conditions, within the capacity of the equipment, as may be requested by the Department. Refer to PADEP Source Testing Program website online for further information related to source testing including Source Testing FAQ and the PADEP Source Testing Manual.

(b) The stack test shall be conducted in accordance with the provisions of the associated USEPA Test Methods, 25 Pa. Code Chapter 139, and the Department's Source Testing Manual (Document No. 274-003-002) Revision 3.3. The stack test shall be performed while all sources operating as part of the Liquid Dispersion Center (Wet Building 2) are operating at maximum normal conditions and ducted to the RTO. The test shall be conducted in order to:

(1) Measure VOC emissions and determine VOC destruction efficiency using USEPA Test Method 25A,

(2) Verify permanent total enclosure (PTE) for all sources ducted to the RTO using USEPA Test Method 204. The facility includes seven (7) enclosures. Each enclosure shall be evaluated separately.

(c) At least ninety (90) days prior to the test, the permittee shall submit to the Department for approval the procedures for the test and a sketch with dimensions indicating the location of sampling ports and other data to ensure the collection of representative samples.

(d) At least thirty (30) days prior to the test, the Regional Air Quality Manager, shall be informed of the date and time of the test.

(e) Within sixty (60) days after the source test(s), one paper copy plus an electronic copy of the complete test report, including all operating conditions, shall be submitted to the Regional Air Quality Manager for approval.

(f) In the event that any of the above deadlines cannot be met, the permittee may request an extension for the due date(s) in writing and include a justification for the extension. The Department may grant an extension for a reasonable cause.

III. MONITORING REQUIREMENTS.**# 003 [25 Pa. Code §127.441]****Operating permit terms and conditions.**

The permittee shall monitor the following operating parameters for the Regenerative Thermal Oxidizer (Source ID C03) on a

**SECTION D. Source Level Requirements**

continuous basis:

- (a) Combustion chamber temperature;
- (b) Air flow rate of the sources ducted to the Regenerative Thermal Oxidizer;
- (c) The time(s) and date(s) of operation.

IV. RECORDKEEPING REQUIREMENTS.

004 [25 Pa. Code §127.441]

Operating permit terms and conditions.

The permittee shall maintain a record of the source test reports for the stack tests performed on this source.

005 [25 Pa. Code §127.441]

Operating permit terms and conditions.

The permittee shall record the following operating parameters for the Regenerative Thermal Oxidizer (Source ID C03) every 15 minutes:

- (a) Combustion chamber temperature, on a 3-hour average basis;
- (b) Total air flow rate of the sources ducted to the Regenerative Thermal Oxidizer, on a 3-hour average basis;
- (c) The time(s) and date(s) of operation.

006 [25 Pa. Code §127.441]

Operating permit terms and conditions.

The permittee shall keep annual records of the following for this RTO:

- (a) inspections performed,
- (b) maintenance performed,
- (c) any deficiencies, and
- (d) any corrective actions taken.

V. REPORTING REQUIREMENTS.

No additional reporting requirements exist except as provided in other sections of this permit including Section B (State Only General Requirements).

VI. WORK PRACTICE REQUIREMENTS.

007 [25 Pa. Code §127.441]

Operating permit terms and conditions.

The permittee shall maintain and operate the RTO in accordance with manufacturer's specifications.

008 [25 Pa. Code §127.441]

Operating permit terms and conditions.

The permittee shall not operate any source if the air flow to the Regenerative Thermal Oxidizer (RTO) (Source ID C03) exceeds 57,000 SCFM, on a 3-hour average basis.

009 [25 Pa. Code §127.441]

Operating permit terms and conditions.

The permittee shall operate the RTO at a 3-hour average temperature not lower than the 3-hour average temperature demonstrated during the most recent compliant source test approved by DEP.

[Note: During the most recent acceptable source test conducted on January 21, 2020, the RTO achieved compliance while operating at a 3-hour average temperature of 1450°F. This temperature requirement shall be in effect until the results of the December 17, 2024 source test are reviewed and found acceptable by DEP Source Testing Section.]

**SECTION D. Source Level Requirements****VII. ADDITIONAL REQUIREMENTS.****# 010 [25 Pa. Code §127.441]****Operating permit terms and conditions.**

(a) All sources operating as part of the Liquid Dispersion Center located in Wet Building 2 (Source ID 200) are routed to the RTO.

(b) The parts washers listed in Source ID 214 (Building 2 Parts Washers) are routed to the RTO [pursuant to 25 Pa. Code § 129.51].

**SECTION D. Source Level Requirements**

Source ID: C04

Source Name: DUST COLLECTOR, DRY BUILDING A/B

Source Capacity/Throughput:

N/A

Conditions for this source occur in the following groups: GROUP 1
GROUP 3

I. RESTRICTIONS.**Emission Restriction(s).****# 001 [25 Pa. Code §127.441]****Operating permit terms and conditions.**

The permittee shall limit post-control PM emissions from this dust collector to 4.0 tons per year, based on a 12-month rolling sum.

[The PM emission limit of 4.0 tpy is the post-control sum of particulate matter emissions from all sources vented to this dust collector.]

II. TESTING REQUIREMENTS.

No additional testing requirements exist except as provided in other sections of this permit including Section B (State Only General Requirements) and/or Section E (Source Group Restrictions).

III. MONITORING REQUIREMENTS.

No additional monitoring requirements exist except as provided in other sections of this permit including Section B (State Only General Requirements) and/or Section E (Source Group Restrictions).

IV. RECORDKEEPING REQUIREMENTS.

No additional record keeping requirements exist except as provided in other sections of this permit including Section B (State Only General Requirements) and/or Section E (Source Group Restrictions).

V. REPORTING REQUIREMENTS.

No additional reporting requirements exist except as provided in other sections of this permit including Section B (State Only General Requirements) and/or Section E (Source Group Restrictions).

VI. WORK PRACTICE REQUIREMENTS.**# 002 [25 Pa. Code §127.441]****Operating permit terms and conditions.**

(a) The permittee shall maintain and operate this dust collector at a pressure drop of 0.5 to 6.5 inches water guage.

(b) The permittee shall not operate any source ducted to this dust collector and take corrective action if the pressure drop is not within 0.5 and 6.5 inches water guage, and/or if the dust collector is not operating properly.

VII. ADDITIONAL REQUIREMENTS.**# 003 [25 Pa. Code §127.441]****Operating permit terms and conditions.**

The equipment contained in Source ID 109, Source ID 115, Source ID 116, and Source ID 212 are ducted to this Dry Building Dust Collector A/B (C04), as follows:

(a) Source ID 109 consists of the following process equipment located in the Dry Building:
Mixer B1,

**SECTION D. Source Level Requirements**

Mixer B2,
Roll Mill B 50",
Extruder E5 36 mm,
Extruder E7 53 mm,
Extruder E9 40 mm,
Extruder E11,
Lab Hoods.

(b) Source ID 115 consists of Extruder E4, E6, and E8 located in the Dry Building.

(c) Source ID 116 consists of Extruder E15 located in the Dry Building.

(d) Source ID 212 consists of Extruder E10 located in the Dry Building.

(e) Extruder 14 E14.

(f) Extruders E18 and E19, Mixers M1 and M2, and Loading Lines L1 and L2.

**SECTION D. Source Level Requirements**

Source ID: C102

Source Name: DUST COLLECTOR WET C1

Source Capacity/Throughput:

N/A

Conditions for this source occur in the following groups: GROUP 2

I. RESTRICTIONS.

No additional requirements exist except as provided in other sections of this permit including Section B (State Only General Requirements) and/or Section E (Source Group Restrictions).

II. TESTING REQUIREMENTS.

No additional testing requirements exist except as provided in other sections of this permit including Section B (State Only General Requirements) and/or Section E (Source Group Restrictions).

III. MONITORING REQUIREMENTS.

No additional monitoring requirements exist except as provided in other sections of this permit including Section B (State Only General Requirements) and/or Section E (Source Group Restrictions).

IV. RECORDKEEPING REQUIREMENTS.

No additional record keeping requirements exist except as provided in other sections of this permit including Section B (State Only General Requirements) and/or Section E (Source Group Restrictions).

V. REPORTING REQUIREMENTS.

No additional reporting requirements exist except as provided in other sections of this permit including Section B (State Only General Requirements) and/or Section E (Source Group Restrictions).

VI. WORK PRACTICE REQUIREMENTS.

No additional work practice requirements exist except as provided in other sections of this permit including Section B (State Only General Requirements) and/or Section E (Source Group Restrictions).

VII. ADDITIONAL REQUIREMENTS.**# 001 [25 Pa. Code §127.441]****Operating permit terms and conditions.**

The following equipment contained in Source ID 102 located in Wing C are ducted to this dust collector:

HSDC1 High Speed Dispenser C Wing 150 gal 1;
 HSDC11 High Speed Dispenser C Wing 500 gal 11;
 HSDC13 High Speed Dispenser C Wing 500 gal 13;
 HSDC3 High Speed Dispenser C Wing 650 gal 3;
 HSDC5 High Speed Dispenser C Wing 200 gal 5;
 HSDC7 High Speed Dispenser C Wing 500 gal 7;
 HSDC9 High Speed Dispenser C Wing 300 gal 9;
 TMC1 Turbo Mill C Wing 500 gal 1;
 Cleaning.

**SECTION D. Source Level Requirements**

Source ID: C105

Source Name: DUST COLLECTOR WET D1

Source Capacity/Throughput:

N/A

Conditions for this source occur in the following groups: GROUP 2

I. RESTRICTIONS.

No additional requirements exist except as provided in other sections of this permit including Section B (State Only General Requirements) and/or Section E (Source Group Restrictions).

II. TESTING REQUIREMENTS.

No additional testing requirements exist except as provided in other sections of this permit including Section B (State Only General Requirements) and/or Section E (Source Group Restrictions).

III. MONITORING REQUIREMENTS.

No additional monitoring requirements exist except as provided in other sections of this permit including Section B (State Only General Requirements) and/or Section E (Source Group Restrictions).

IV. RECORDKEEPING REQUIREMENTS.

No additional record keeping requirements exist except as provided in other sections of this permit including Section B (State Only General Requirements) and/or Section E (Source Group Restrictions).

V. REPORTING REQUIREMENTS.

No additional reporting requirements exist except as provided in other sections of this permit including Section B (State Only General Requirements) and/or Section E (Source Group Restrictions).

VI. WORK PRACTICE REQUIREMENTS.

No additional work practice requirements exist except as provided in other sections of this permit including Section B (State Only General Requirements) and/or Section E (Source Group Restrictions).

VII. ADDITIONAL REQUIREMENTS.**# 001 [25 Pa. Code §127.441]****Operating permit terms and conditions.**

The equipment contained in Source ID 105 and Source ID 106 are ducted to this dust collector as follows:

Source ID 105:

SBME1 Steel Ball Mill (Enclosed Mixing Vessel) E Wing 650 gal 1;

BME1 Basket Mill Wing E;

Wash Sinks and Cleaning.

Source ID 106:

RMF2 Roll Mill F Wing 60" 2;

BPF5 Baker Perkins (Horizontal Mixer) F Wing 150 gal 5;

BPF6 Baker Perkins (Horizontal Mixer) F Wing 150 gal 6;

BPF1 Baker Perkins (Horizontal Mixer) F Wing 150 gal 1;

RMF1 Roll Mill F Wing 60" 1;

BPF2 Baker Perkins (Horizontal Mixer) F Wing 150 gal;

BPF3 Baker Perkins (Horizontal Mixer) F Wing 25 gal;

BPF4 (113) Baker Perkins (Mixer) F Wing 75 gal;

**SECTION D. Source Level Requirements**

Wash Sinks and Cleaning.

HSD E1

HSD E2

CT E1

CT E2.

**SECTION D. Source Level Requirements**

Source ID: C110

Source Name: DUST COLLECTOR, 12000 CFM, DRY C/D LINE, FOR 110

Source Capacity/Throughput:

N/A

Conditions for this source occur in the following groups: GROUP 1

I. RESTRICTIONS.

No additional requirements exist except as provided in other sections of this permit including Section B (State Only General Requirements) and/or Section E (Source Group Restrictions).

II. TESTING REQUIREMENTS.

No additional testing requirements exist except as provided in other sections of this permit including Section B (State Only General Requirements) and/or Section E (Source Group Restrictions).

III. MONITORING REQUIREMENTS.

No additional monitoring requirements exist except as provided in other sections of this permit including Section B (State Only General Requirements) and/or Section E (Source Group Restrictions).

IV. RECORDKEEPING REQUIREMENTS.

No additional record keeping requirements exist except as provided in other sections of this permit including Section B (State Only General Requirements) and/or Section E (Source Group Restrictions).

V. REPORTING REQUIREMENTS.

No additional reporting requirements exist except as provided in other sections of this permit including Section B (State Only General Requirements) and/or Section E (Source Group Restrictions).

VI. WORK PRACTICE REQUIREMENTS.**# 001 [25 Pa. Code §127.441]****Operating permit terms and conditions.**

(a) The permittee shall maintain and operate this dust collector at a pressure drop of 0.5 to 6.5 inches water guage.

(b) The permittee shall not operate any source ducted to this dust collector and take corrective action if the pressure drop is not within 0.5 and 6.5 inches water guage, and/or if the dust collector is not operating properly.

VII. ADDITIONAL REQUIREMENTS.**# 002 [25 Pa. Code §127.441]****Operating permit terms and conditions.**

The equipment contained in Source ID 110 are ducted to this Dry Building Dust Collector C110, as follows:

Roll Mill C
 Roll Mill G (60"),
 Chipper D2 (20 HP),
 Chipper D3 (30 HP),
 Mixer D2 (30 cu ft.),
 Pulverizer D1 (20 HP),
 Pulverizer D2 (30 HP),
 Blender F.

**SECTION D. Source Level Requirements**

Source ID: C111

Source Name: DUST COLLECTOR 7,500 CFM, DRY C1, C2 FOR 111

Source Capacity/Throughput:

N/A

Conditions for this source occur in the following groups: GROUP 1

I. RESTRICTIONS.

No additional requirements exist except as provided in other sections of this permit including Section B (State Only General Requirements) and/or Section E (Source Group Restrictions).

II. TESTING REQUIREMENTS.

No additional testing requirements exist except as provided in other sections of this permit including Section B (State Only General Requirements) and/or Section E (Source Group Restrictions).

III. MONITORING REQUIREMENTS.

No additional monitoring requirements exist except as provided in other sections of this permit including Section B (State Only General Requirements) and/or Section E (Source Group Restrictions).

IV. RECORDKEEPING REQUIREMENTS.

No additional record keeping requirements exist except as provided in other sections of this permit including Section B (State Only General Requirements) and/or Section E (Source Group Restrictions).

V. REPORTING REQUIREMENTS.

No additional reporting requirements exist except as provided in other sections of this permit including Section B (State Only General Requirements) and/or Section E (Source Group Restrictions).

VI. WORK PRACTICE REQUIREMENTS.**# 001 [25 Pa. Code §127.441]****Operating permit terms and conditions.**

(a) The permittee shall maintain and operate this dust collector at a pressure drop of 0.5 to 6.5 inches water guage.

(b) The permittee shall not operate any source ducted to this dust collector and take corrective action if the pressure drop is not within 0.5 and 6.5 inches water guage, and/or if the dust collector is not operating properly.

VII. ADDITIONAL REQUIREMENTS.**# 002 [25 Pa. Code §127.441]****Operating permit terms and conditions.**

The equipment contained in Source ID 111 are ducted to Dry Building Dust Collector C111 and C112A, as follows:

Continuous Line C1 Dry Building, 500 lbs
Continuous Line C2 Dry Building, 150 HP.

**SECTION D. Source Level Requirements**

Source ID: C112A

Source Name: DUST COLLECTOR, 10,000 CFM, DRY C LINE C1 C2 AND C3

Source Capacity/Throughput:

N/A

Conditions for this source occur in the following groups: GROUP 1

I. RESTRICTIONS.

No additional requirements exist except as provided in other sections of this permit including Section B (State Only General Requirements) and/or Section E (Source Group Restrictions).

II. TESTING REQUIREMENTS.

No additional testing requirements exist except as provided in other sections of this permit including Section B (State Only General Requirements) and/or Section E (Source Group Restrictions).

III. MONITORING REQUIREMENTS.

No additional monitoring requirements exist except as provided in other sections of this permit including Section B (State Only General Requirements) and/or Section E (Source Group Restrictions).

IV. RECORDKEEPING REQUIREMENTS.

No additional record keeping requirements exist except as provided in other sections of this permit including Section B (State Only General Requirements) and/or Section E (Source Group Restrictions).

V. REPORTING REQUIREMENTS.

No additional reporting requirements exist except as provided in other sections of this permit including Section B (State Only General Requirements) and/or Section E (Source Group Restrictions).

VI. WORK PRACTICE REQUIREMENTS.**# 001 [25 Pa. Code §127.441]****Operating permit terms and conditions.**

(a) The permittee shall maintain and operate this dust collector at a pressure drop of 0.5 to 6.5 inches water guage.

(b) The permittee shall not operate any source ducted to this dust collector and take corrective action if the pressure drop is not within 0.5 and 6.5 inches water guage, and/or if the dust collector is not operating properly.

VII. ADDITIONAL REQUIREMENTS.**# 002 [25 Pa. Code §127.441]****Operating permit terms and conditions.**

The equipment contained in Source ID 111 and Source ID 112 are ducted to this Dry Building Dust Collector C112A as follows:

Source ID 111: Continuous Line C1 Dry Building (500 lbs), and Continuous Line C2 Dry Building (150 HP), and

Source ID 112: Continuous Line C3 (500 lbs).

**SECTION D. Source Level Requirements**

Source ID: C112B

Source Name: DUST COLLECTOR 1,800 CFM, DRY C3

Source Capacity/Throughput:

N/A

Conditions for this source occur in the following groups: GROUP 1

I. RESTRICTIONS.

No additional requirements exist except as provided in other sections of this permit including Section B (State Only General Requirements) and/or Section E (Source Group Restrictions).

II. TESTING REQUIREMENTS.

No additional testing requirements exist except as provided in other sections of this permit including Section B (State Only General Requirements) and/or Section E (Source Group Restrictions).

III. MONITORING REQUIREMENTS.

No additional monitoring requirements exist except as provided in other sections of this permit including Section B (State Only General Requirements) and/or Section E (Source Group Restrictions).

IV. RECORDKEEPING REQUIREMENTS.

No additional record keeping requirements exist except as provided in other sections of this permit including Section B (State Only General Requirements) and/or Section E (Source Group Restrictions).

V. REPORTING REQUIREMENTS.

No additional reporting requirements exist except as provided in other sections of this permit including Section B (State Only General Requirements) and/or Section E (Source Group Restrictions).

VI. WORK PRACTICE REQUIREMENTS.**# 001 [25 Pa. Code §127.441]****Operating permit terms and conditions.**

(a) The permittee shall maintain and operate this dust collector at a pressure drop of 0.5 to 6.5 inches water guage.

(b) The permittee shall not operate any source ducted to this dust collector and take corrective action if the pressure drop is not within 0.5 and 6.5 inches water guage, and/or if the dust collector is not operating properly.

VII. ADDITIONAL REQUIREMENTS.**# 002 [25 Pa. Code §127.441]****Operating permit terms and conditions.**

The equipment contained in Source ID 112 (Continuous Line C3, 500 lbs) is ducted to this Dry Building Dust Collector C112B.

**SECTION D. Source Level Requirements**

Source ID: C113

Source Name: DUST COLLECTOR 2,150 CFM, DRY C5, FOR 113

Source Capacity/Throughput:

N/A

Conditions for this source occur in the following groups: GROUP 1

I. RESTRICTIONS.

No additional requirements exist except as provided in other sections of this permit including Section B (State Only General Requirements) and/or Section E (Source Group Restrictions).

II. TESTING REQUIREMENTS.

No additional testing requirements exist except as provided in other sections of this permit including Section B (State Only General Requirements) and/or Section E (Source Group Restrictions).

III. MONITORING REQUIREMENTS.

No additional monitoring requirements exist except as provided in other sections of this permit including Section B (State Only General Requirements) and/or Section E (Source Group Restrictions).

IV. RECORDKEEPING REQUIREMENTS.

No additional record keeping requirements exist except as provided in other sections of this permit including Section B (State Only General Requirements) and/or Section E (Source Group Restrictions).

V. REPORTING REQUIREMENTS.

No additional reporting requirements exist except as provided in other sections of this permit including Section B (State Only General Requirements) and/or Section E (Source Group Restrictions).

VI. WORK PRACTICE REQUIREMENTS.**# 001 [25 Pa. Code §127.441]****Operating permit terms and conditions.**

(a) The permittee shall maintain and operate this dust collector at a pressure drop of 0.5 to 6.5 inches water guage.

(b) The permittee shall not operate any source ducted to this dust collector and take corrective action if the pressure drop is not within 0.5 and 6.5 inches water guage, and/or if the dust collector is not operating properly.

VII. ADDITIONAL REQUIREMENTS.**# 002 [25 Pa. Code §127.441]****Operating permit terms and conditions.**

The equipment contained in Source ID 113 is ducted to this Dry Building Dust Collector C113, as follows:

Continuous Line C5 (60 lbs) and Pulverizer C5 (40 HP).

**SECTION D. Source Level Requirements**

Source ID: C114

Source Name: DUST COLLECTOR 5,000 CFM, DRY PM ROOM, FOR 114

Source Capacity/Throughput:

N/A

Conditions for this source occur in the following groups: GROUP 1

I. RESTRICTIONS.

No additional requirements exist except as provided in other sections of this permit including Section B (State Only General Requirements) and/or Section E (Source Group Restrictions).

II. TESTING REQUIREMENTS.

No additional testing requirements exist except as provided in other sections of this permit including Section B (State Only General Requirements) and/or Section E (Source Group Restrictions).

III. MONITORING REQUIREMENTS.

No additional monitoring requirements exist except as provided in other sections of this permit including Section B (State Only General Requirements) and/or Section E (Source Group Restrictions).

IV. RECORDKEEPING REQUIREMENTS.

No additional record keeping requirements exist except as provided in other sections of this permit including Section B (State Only General Requirements) and/or Section E (Source Group Restrictions).

V. REPORTING REQUIREMENTS.

No additional reporting requirements exist except as provided in other sections of this permit including Section B (State Only General Requirements) and/or Section E (Source Group Restrictions).

VI. WORK PRACTICE REQUIREMENTS.**# 001 [25 Pa. Code §127.441]****Operating permit terms and conditions.**

(a) The permittee shall maintain and operate this dust collector at a pressure drop of 0.5 to 6.5 inches water guage.

(b) The permittee shall not operate any source ducted to this dust collector and take corrective action if the pressure drop is not within 0.5 and 6.5 inches water guage, and/or if the dust collector is not operating properly.

VII. ADDITIONAL REQUIREMENTS.**# 002 [25 Pa. Code §127.441]****Operating permit terms and conditions.**

The equipment contained in Source ID 114 are ducted to this Dry Building Dust Collector C114, as follows:

Blender B30 (Premix Room) 30 cu ft,

Henschel H10 Premixer

Henschel H11 High Intensity Mixer (Premix Room) 1200 liter,

Henschel H12 High Intensity Mixer (Premix Room) 600 liter,

Mixer B60 Mixer (Premix Room) 60 cu ft,

Mixer B90 Mixer (Premix Room) 90 cu ft.

**SECTION D. Source Level Requirements**

Source ID: C118A

Source Name: DUST COLLECTOR, 3,500 CFM, DRY CONTINUOUS LINE C4

Source Capacity/Throughput:

N/A

Conditions for this source occur in the following groups: GROUP 1

I. RESTRICTIONS.

No additional requirements exist except as provided in other sections of this permit including Section B (State Only General Requirements) and/or Section E (Source Group Restrictions).

II. TESTING REQUIREMENTS.

No additional testing requirements exist except as provided in other sections of this permit including Section B (State Only General Requirements) and/or Section E (Source Group Restrictions).

III. MONITORING REQUIREMENTS.

No additional monitoring requirements exist except as provided in other sections of this permit including Section B (State Only General Requirements) and/or Section E (Source Group Restrictions).

IV. RECORDKEEPING REQUIREMENTS.

No additional record keeping requirements exist except as provided in other sections of this permit including Section B (State Only General Requirements) and/or Section E (Source Group Restrictions).

V. REPORTING REQUIREMENTS.

No additional reporting requirements exist except as provided in other sections of this permit including Section B (State Only General Requirements) and/or Section E (Source Group Restrictions).

VI. WORK PRACTICE REQUIREMENTS.**# 001 [25 Pa. Code §127.441]****Operating permit terms and conditions.**

(a) The permittee shall maintain and operate this dust collector at a pressure drop of 0.5 to 6.5 inches water guage.

(b) The permittee shall not operate any source ducted to this dust collector and take corrective action if the pressure drop is not within 0.5 and 6.5 inches water guage, and/or if the dust collector is not operating properly.

VII. ADDITIONAL REQUIREMENTS.**# 002 [25 Pa. Code §127.441]****Operating permit terms and conditions.**

The equipment contained in Source ID 118 are ducted to this Dry Building Dust Collector C118A, as follows:

Continuous Line C4 80 lbs and C4 Pulverizer.

**SECTION D. Source Level Requirements**

Source ID: C205

Source Name: DUST COLLECTOR, DRY BUILDING HENSCHEL

Source Capacity/Throughput:

N/A

Conditions for this source occur in the following groups: GROUP 1
GROUP 3

I. RESTRICTIONS.**Emission Restriction(s).****# 001 [25 Pa. Code §127.441]****Operating permit terms and conditions.**

The permittee shall limit post-control particulate matter (as PM10/PM2.5) emissions from this dust collector to 2.3 tons per year, based on a 12-month rolling sum.

[The PM emission limit of 2.3 tpy is the post-control sum of PM10/PM2.5 emissions from all sources vented to this dust collector.]

II. TESTING REQUIREMENTS.

No additional testing requirements exist except as provided in other sections of this permit including Section B (State Only General Requirements) and/or Section E (Source Group Restrictions).

III. MONITORING REQUIREMENTS.

No additional monitoring requirements exist except as provided in other sections of this permit including Section B (State Only General Requirements) and/or Section E (Source Group Restrictions).

IV. RECORDKEEPING REQUIREMENTS.

No additional record keeping requirements exist except as provided in other sections of this permit including Section B (State Only General Requirements) and/or Section E (Source Group Restrictions).

V. REPORTING REQUIREMENTS.

No additional reporting requirements exist except as provided in other sections of this permit including Section B (State Only General Requirements) and/or Section E (Source Group Restrictions).

VI. WORK PRACTICE REQUIREMENTS.**# 002 [25 Pa. Code §127.441]****Operating permit terms and conditions.**

(a) The permittee shall maintain and operate this dust collector at a pressure drop of 0.5 to 6.5 inches water guage.

(b) The permittee shall not operate any source ducted to this dust collector and take corrective action if the pressure drop is not within 0.5 and 6.5 inches water guage, and/or if the dust collector is not operating properly.

VII. ADDITIONAL REQUIREMENTS.**# 003 [25 Pa. Code §127.441]****Operating permit terms and conditions.**

The following sources are ducted to the Dry Building Henschel Dust Collector C205:

Source ID 121: Dry Building Extruder E12

Source ID 205: High Intensity Mixer H8

Source ID 206: High Intensity Mixer H9

**SECTION D. Source Level Requirements**

Extruder E16, and E16 Hand-Loading
Roll Mill E
Henschel H5
Henschel H1
Henschel H2
Pulverizers
Extruder CM1
Extruder CM2
Extruder F4
Extruder F4
Extruder E17 with mixer

**SECTION D. Source Level Requirements**

Source ID: C209

Source Name: DUST COLLECTOR, WET BUILDING, D-WING #1

Source Capacity/Throughput:

N/A

Conditions for this source occur in the following groups: GROUP 2

I. RESTRICTIONS.

No additional requirements exist except as provided in other sections of this permit including Section B (State Only General Requirements) and/or Section E (Source Group Restrictions).

II. TESTING REQUIREMENTS.

No additional testing requirements exist except as provided in other sections of this permit including Section B (State Only General Requirements) and/or Section E (Source Group Restrictions).

III. MONITORING REQUIREMENTS.

No additional monitoring requirements exist except as provided in other sections of this permit including Section B (State Only General Requirements) and/or Section E (Source Group Restrictions).

IV. RECORDKEEPING REQUIREMENTS.

No additional record keeping requirements exist except as provided in other sections of this permit including Section B (State Only General Requirements) and/or Section E (Source Group Restrictions).

V. REPORTING REQUIREMENTS.

No additional reporting requirements exist except as provided in other sections of this permit including Section B (State Only General Requirements) and/or Section E (Source Group Restrictions).

VI. WORK PRACTICE REQUIREMENTS.

No additional work practice requirements exist except as provided in other sections of this permit including Section B (State Only General Requirements) and/or Section E (Source Group Restrictions).

VII. ADDITIONAL REQUIREMENTS.**# 001 [25 Pa. Code §127.441]****Operating permit terms and conditions.**

The equipment contained in Source ID 123, Source ID 209, and Source ID 210 and are ducted to this dust collector as follows:

Source ID 123: Wet Building Pre-Mix Dispenser PMDD4,
 Source ID 209: Wet Building Pre-Mix Dispenser PMDD1 (5000 liter)
 Source ID 210: Wet Building Pre-Mix Dispenser PMDD2 (5000 liter).

**SECTION D. Source Level Requirements**

Source ID: C211

Source Name: DUST COLLECTOR, WET BUILDING, D-WING #2

Source Capacity/Throughput:

N/A

Conditions for this source occur in the following groups: GROUP 2
GROUP 3

I. RESTRICTIONS.**Emission Restriction(s).****# 001 [25 Pa. Code §127.441]****Operating permit terms and conditions.**

The permittee shall limit post-control PM emissions from this dust collector to 1.0 tons per year, based on 12-month rolling sum.

[The PM emission limit of 1.0 tpy is the post-control sum of particulate matter emissions from all sources vented to this dust collector.]

II. TESTING REQUIREMENTS.

No additional testing requirements exist except as provided in other sections of this permit including Section B (State Only General Requirements) and/or Section E (Source Group Restrictions).

III. MONITORING REQUIREMENTS.

No additional monitoring requirements exist except as provided in other sections of this permit including Section B (State Only General Requirements) and/or Section E (Source Group Restrictions).

IV. RECORDKEEPING REQUIREMENTS.

No additional record keeping requirements exist except as provided in other sections of this permit including Section B (State Only General Requirements) and/or Section E (Source Group Restrictions).

V. REPORTING REQUIREMENTS.

No additional reporting requirements exist except as provided in other sections of this permit including Section B (State Only General Requirements) and/or Section E (Source Group Restrictions).

VI. WORK PRACTICE REQUIREMENTS.

No additional work practice requirements exist except as provided in other sections of this permit including Section B (State Only General Requirements) and/or Section E (Source Group Restrictions).

VII. ADDITIONAL REQUIREMENTS.**# 002 [25 Pa. Code §127.441]****Operating permit terms and conditions.**

Source ID 211 (Wet Building Pre-Mix Dispenser PMDD3 2500 Liter) is ducted to this dust collector (C211).

**SECTION D. Source Level Requirements**

Source ID: C213

Source Name: DUST COLLECTOR R 12,000 CFM DRY BUILDING

Source Capacity/Throughput:

N/A

Conditions for this source occur in the following groups: GROUP 1

I. RESTRICTIONS.

No additional requirements exist except as provided in other sections of this permit including Section B (State Only General Requirements) and/or Section E (Source Group Restrictions).

II. TESTING REQUIREMENTS.

No additional testing requirements exist except as provided in other sections of this permit including Section B (State Only General Requirements) and/or Section E (Source Group Restrictions).

III. MONITORING REQUIREMENTS.

No additional monitoring requirements exist except as provided in other sections of this permit including Section B (State Only General Requirements) and/or Section E (Source Group Restrictions).

IV. RECORDKEEPING REQUIREMENTS.

No additional record keeping requirements exist except as provided in other sections of this permit including Section B (State Only General Requirements) and/or Section E (Source Group Restrictions).

V. REPORTING REQUIREMENTS.

No additional reporting requirements exist except as provided in other sections of this permit including Section B (State Only General Requirements) and/or Section E (Source Group Restrictions).

VI. WORK PRACTICE REQUIREMENTS.**[25 Pa. Code §127.441]****Operating permit terms and conditions.**

(a) The permittee shall maintain and operate this dust collector at a pressure drop of 0 - 8.0 inches water guage.

(b) The permittee shall not operate any source ducted to this dust collector and take corrective action if the pressure drop is not within 0 and 8.0 inches water guage, and/or if the dust collector is not operating properly.

VII. ADDITIONAL REQUIREMENTS.**[25 Pa. Code §127.441]****Operating permit terms and conditions.**

The equipment contained in Source ID 213 are ducted to this Dry Building Dust Collector C213, as follows:

Continuous C6 Line (mixing, extrusion, and pulverizing)

Weight set up (multiple stations)

Resin Loading 1

Resin Loading 2.

**SECTION E. Source Group Restrictions.**

Group Name: GROUP 1

Group Description: Dry Building 1 Dust Collectors

Sources included in this group

ID	Name
C04	DUST COLLECTOR, DRY BUILDING A/B
C110	DUST COLLECTOR, 12000 CFM, DRY C/D LINE, FOR 110
C111	DUST COLLECTOR 7,500 CFM, DRY C1, C2 FOR 111
C112A	DUST COLLECTOR, 10,000 CFM, DRY C LINE C1 C2 AND C3
C112B	DUST COLLECTOR 1,800 CFM, DRY C3
C113	DUST COLLECTOR 2,150 CFM, DRY C5, FOR 113
C114	DUST COLLECTOR 5,000 CFM, DRY PM ROOM, FOR 114
C118A	DUST COLLECTOR, 3,500 CFM, DRY CONTINUOUS LINE C4
C205	DUST COLLECTOR, DRY BUILDING HENSCHEL
C213	DUST COLLECTOR R 12,000 CFM DRY BUILDING

I. RESTRICTIONS.**Control Device Efficiency Restriction(s).**

001 [25 Pa. Code §127.441]

Operating permit terms and conditions.

The permittee shall maintain a control equipment removal efficiency of 99.9% for this dust collector.

[The method of compliance for this condition is listed in work practice standards for this source.]

II. TESTING REQUIREMENTS.

No additional testing requirements exist except as provided in other sections of this permit including Section B (State Only General Requirements).

III. MONITORING REQUIREMENTS.

002 [25 Pa. Code §127.441]

Operating permit terms and conditions.

The permittee shall monitor the pressure drop across this dust collector on a continuous basis through the use of a magnahelic pressure drop gauge instrument.

IV. RECORDKEEPING REQUIREMENTS.

003 [25 Pa. Code §127.441]

Operating permit terms and conditions.

The permittee shall keep weekly records of the following for this dust collector:

- (a) inspections performed,
- (b) maintenance performed (including when filters are replaced),
- (c) any deficiencies, and
- (d) any corrective actions taken.

004 [25 Pa. Code §127.441]

Operating permit terms and conditions.

The permittee shall maintain weekly records of the pressure drop readings across this dust collector.

V. REPORTING REQUIREMENTS.

No additional reporting requirements exist except as provided in other sections of this permit including Section B (State Only General Requirements).

**SECTION E. Source Group Restrictions.****VI. WORK PRACTICE REQUIREMENTS.****# 005 [25 Pa. Code §127.441]****Operating permit terms and conditions.**

The permittee shall operate and maintain this dust collector according to good air pollution control practices.

006 [25 Pa. Code §127.441]**Operating permit terms and conditions.**

- (a) The permittee shall inspect the dust collector on a weekly basis to ensure proper operation of the unit.
- (b) The permittee shall keep spare filters on hand for replacement.
- (c) The permittee shall replace filters and/or clean filters as needed, based on pressure drop readings falling outside of the pressure drop range or as a result of routine inspection/maintenance.

VII. ADDITIONAL REQUIREMENTS.

No additional requirements exist except as provided in other sections of this permit including Section B (State Only General Requirements).

**SECTION E. Source Group Restrictions.**

Group Name: GROUP 2

Group Description: Wet Building 2 Dust Collectors

Sources included in this group

ID	Name
C01	DUST COLLECTOR, WET BUILDING, LARGE PRE-OXY
C102	DUST COLLECTOR WET C1
C105	DUST COLLECTOR WET D1
C209	DUST COLLECTOR, WET BUILDING, D-WING #1
C211	DUST COLLECTOR, WET BUILDING, D-WING #2

I. RESTRICTIONS.**Throughput Restriction(s).**

001 [25 Pa. Code §127.441]

Operating permit terms and conditions.

The permittee shall maintain a control equipment removal efficiency of 99.9% for this dust collector.

[The method of compliance for this condition is listed in work practice standards for this source.]

II. TESTING REQUIREMENTS.

No additional testing requirements exist except as provided in other sections of this permit including Section B (State Only General Requirements).

III. MONITORING REQUIREMENTS.

002 [25 Pa. Code §127.441]

Operating permit terms and conditions.

The permittee shall monitor the pressure drop across this dust collector on a continuous basis through the use of a magnahelic pressure drop gauge instrument.

IV. RECORDKEEPING REQUIREMENTS.

003 [25 Pa. Code §127.441]

Operating permit terms and conditions.

The permittee shall keep weekly records of the following for this dust collector:

- (a) inspections performed,
- (b) maintenance performed (including when filters are replaced),
- (c) any deficiencies, and
- (d) any corrective actions taken.

004 [25 Pa. Code §127.441]

Operating permit terms and conditions.

The permittee shall maintain weekly records of the pressure drop readings across this dust collector.

V. REPORTING REQUIREMENTS.

No additional reporting requirements exist except as provided in other sections of this permit including Section B (State Only General Requirements).

VI. WORK PRACTICE REQUIREMENTS.

005 [25 Pa. Code §127.441]

Operating permit terms and conditions.

- (a) The permittee shall maintain and operate this dust collector at a pressure drop of 0.5 to 6.5 inches water guage.
- (b) The permittee shall not operate any source ducted to this dust collector and take corrective action if the pressure drop is not within 0.5 and 6.5 inches water guage, and/or if the dust collector is not operating properly.

**SECTION E. Source Group Restrictions.****# 006 [25 Pa. Code §127.441]****Operating permit terms and conditions.**

The permittee shall operate and maintain this dust collector according to good air pollution control practices.

007 [25 Pa. Code §127.441]**Operating permit terms and conditions.**

- (a) The permittee shall inspect the dust collector on a weekly basis to ensure proper operation of the unit.
- (b) The permittee shall keep spare filters on hand for replacement.
- (c) The permittee shall replace filters and/or clean filters as needed, based on pressure drop readings falling outside of the pressure drop range or as a result of routine inspection/maintenance.

VII. ADDITIONAL REQUIREMENTS.

No additional requirements exist except as provided in other sections of this permit including Section B (State Only General Requirements).

**SECTION E. Source Group Restrictions.**

Group Name: GROUP 3

Group Description: Dust Collectors with PM TYPY Limit

Sources included in this group

ID	Name
C01	DUST COLLECTOR, WET BUILDING, LARGE PRE-OXY
C04	DUST COLLECTOR, DRY BUILDING A/B
C205	DUST COLLECTOR, DRY BUILDING HENSCHEL
C211	DUST COLLECTOR, WET BUILDING, D-WING #2

I. RESTRICTIONS.

No additional requirements exist except as provided in other sections of this permit including Section B (State Only General Requirements).

II. TESTING REQUIREMENTS.

No additional testing requirements exist except as provided in other sections of this permit including Section B (State Only General Requirements).

III. MONITORING REQUIREMENTS.**# 001 [25 Pa. Code §127.441]****Operating permit terms and conditions.**

The permittee shall base total post-control particulate matter emission calculations (tons per year) on actual material throughput (pounds of material per month), control device efficiency, and USEPA AP-42 emission factor for PM (Section 6.4.1) for all sources ducted to this dust collector.

The permittee may submit to the DEP for approval an alternative method for calculation of total post-control particulate matter emissions.

IV. RECORDKEEPING REQUIREMENTS.**# 002 [25 Pa. Code §127.441]****Operating permit terms and conditions.**

The permittee shall maintain monthly records of post-control particulate matter emissions from all process units vented to this dust collector, including 12-month rolling sums.

003 [25 Pa. Code §127.441]**Operating permit terms and conditions.**

The permittee shall maintain the monthly records of material throughput (pounds of material per month) for each process unit ducted to this dust collector.

V. REPORTING REQUIREMENTS.

No additional reporting requirements exist except as provided in other sections of this permit including Section B (State Only General Requirements).

VI. WORK PRACTICE REQUIREMENTS.

No additional work practice requirements exist except as provided in other sections of this permit including Section B (State Only General Requirements).

VII. ADDITIONAL REQUIREMENTS.

No additional requirements exist except as provided in other sections of this permit including Section B (State Only General Requirements).

**SECTION E. Source Group Restrictions.**

Group Name: GROUP 4

Group Description: Fuel Oil Boilers

Sources included in this group

ID	Name
032	DUAL FUEL BOILERS (NG AND NO. 2)
033	NO. 2 FUEL OIL BOILERS

I. RESTRICTIONS.**Emission Restriction(s).****# 001 [25 Pa. Code §123.11]****Combustion units**

A person may not permit the emission into the outdoor atmosphere of particulate matter from a combustion unit in excess of the rate of 0.4 pound per million Btu of heat input, pursuant to 25 Pa. Code § 123.11(a)(1).

[The method of compliance for this permit condition is using proper fuels as approved herein.]

Fuel Restriction(s).**# 002 [25 Pa. Code §123.22]****Combustion units**

A person may not offer for sale, deliver for use, exchange in trade or permit the use of commercial fuel oil in a combustion unit in the Southeast Pennsylvania air basin if the commercial fuel oil contains sulfur in excess of 15 ppm (0.0015%) by weight sulfur content, in accordance with 25 Pa. Code § 123.22(e)(2), except as allowable in 25 Pa. Code § 123.22(e)(2)(ii) and (iii).

[Compliance with this condition demonstrates compliance with the streamlined condition from 25 Pa. Code § 123.22(e)(1), for the outer zone.]

[The method of compliance for this permit condition is the use of proper fuels as approved herein.]

II. TESTING REQUIREMENTS.**# 003 [25 Pa. Code §139.16]****Sulfur in fuel oil.**

(a) The following are applicable to tests for the analysis of commercial fuel oil:

(1) The fuel oil sample for chemical analysis shall be collected in a manner that provides a representative sample. Upon the request of a Department official, the person responsible for the operation of the source shall collect the sample employing the procedures and equipment specified in 25 Pa. Code § 139.4(10) (relating to references).

(2) Test methods and procedures for the determination of viscosity shall be that specified in 25 Pa. Code § 139.4(11) (relating to references). The viscosity shall be determined at 100°F.

(3) Tests methods and procedures for the determination of sulfur shall be those specified in 25 Pa. Code § 139.4(12)--(15).

(4) Results shall be reported in accordance with the units specified in 25 Pa. Code § 123.22 (relating to combustion units).

(b) The testing requirements in subpart (a) above, shall be waived in the event that a delivery receipt from the supplier, showing the percentage sulfur in the fuel, is obtained each time a fuel oil delivery is made.

III. MONITORING REQUIREMENTS.

No additional monitoring requirements exist except as provided in other sections of this permit including Section B (State Only General Requirements).

**SECTION E. Source Group Restrictions.****IV. RECORDKEEPING REQUIREMENTS.****# 004 [25 Pa. Code §123.22]****Combustion units**

(a) The permittee shall maintain in electronic or paper format the record provided by the transferor for the shipment of commercial fuel oil as it changed hands to the permittee (ultimate consumer). This record must legibly and conspicuously contain the following information, in accordance with 25 Pa. Code § 123.22(g)(1) and (5):

- (1) The date of the sale or transfer.
- (2) The name and address of the transferor.
- (3) The name and address of the transferee.
- (4) The volume of commercial fuel oil being sold or transferred.
- (5) The identification of the sulfur content of the shipment of commercial fuel oil, determined using the sampling and testing methods specified in 25 Pa. Code § 123.22(f)(1), expressed as the following statement: For a shipment of No. 2 and lighter commercial fuel oil, "The sulfur content of this shipment is 500 ppm or below."
- (6) The location of the commercial fuel oil at the time of transfer.

(b) The permittee shall maintain the applicable records in electronic or paper format for 5 years in accordance with 25 Pa. Code § 123.22(g)(4)(i).

V. REPORTING REQUIREMENTS.**# 005 [25 Pa. Code §123.22]****Combustion units**

The permittee shall provide an electronic or written copy of the commercial fuel oil shipment record to the Department upon request, in accordance with 25 Pa. Code § 123.22(g)(4)(ii).

VI. WORK PRACTICE REQUIREMENTS.

No additional work practice requirements exist except as provided in other sections of this permit including Section B (State Only General Requirements).

VII. ADDITIONAL REQUIREMENTS.

No additional requirements exist except as provided in other sections of this permit including Section B (State Only General Requirements).

**SECTION F. Alternative Operation Requirements.**

Alternative Operation Name: ZERO VOC MATERIAL

#001 CHANGES FROM NORMAL OPERATION

The exhaust from any unit contained in Source ID 200 may bypass the Regenerative Thermal Oxidizer (C03 RTO) when processing material containing no VOC.

Sources included in this Alternative Operation:

ID	Name	Source Type
200	WET BUILDING 2 - LIQUID DISPERSION CENTER	Process

I. RESTRICTIONS.

No additional requirements exist except as provided in other sections of this permit including Section B (State Only General Requirements).

II. TESTING REQUIREMENTS.

No additional testing requirements exist except as provided in other sections of this permit including Section B (State Only General Requirements).

III. MONITORING REQUIREMENTS.

No additional monitoring requirements exist except as provided in other sections of this permit including Section B (State Only General Requirements).

IV. RECORDKEEPING REQUIREMENTS.

No additional record keeping requirements exist except as provided in other sections of this permit including Section B (State Only General Requirements).

V. REPORTING REQUIREMENTS.

No additional reporting requirements exist except as provided in other sections of this permit including Section B (State Only General Requirements).

VI. WORK PRACTICE REQUIREMENTS.**# 001 [25 Pa. Code §127.441]****Operating permit terms and conditions.**

The exhaust from any unit contained in Source ID 200 may bypass the Regenerative Thermal Oxidizer (C03 RTO) when processing material with zero VOC content. The permittee shall comply with all other existing permit conditions for Source ID 200.

VII. ADDITIONAL REQUIREMENTS.

No additional requirements exist except as provided in other sections of this permit including Section B (State Only General Requirements).

**SECTION G. Emission Restriction Summary.**

Source Id	Source Descriptor
032	DUAL FUEL BOILERS (NG AND NO. 2)
Emission Limit	
0.400 Lbs/MMBTU	PM10
033	NO. 2 FUEL OIL BOILERS
Emission Limit	
0.400 Lbs/MMBTU	PM10
100	DRY BUILDING 1 - PLASTIC MASTERBATCH CENTER
Emission Limit	
0.020 gr/DRY FT3	PM10
6.750 Tons/Yr	12-month rolling sum VOC
126	TWO (2) EMERGENCY GENERATORS
Emission Limit	
2.750 Tons/OZNESEAS	NOX
6.600 Tons/Yr	based on a 12-month rolling sum NOX
100.000 Lbs/Hr	NOX
1,000.000 Lbs/Day	NOX
0.040 gr/DRY FT3	PM10
500.000 PPMV	SOX
200	WET BUILDING 2 - LIQUID DISPERSION CENTER
Emission Limit	
0.020 gr/DRY FT3	PM10
13.900 Tons/Yr	based on a 12-month rolling sum VOC
C01	DUST COLLECTOR, WET BUILDING, LARGE PRE-OXY
Emission Limit	
8.100 Tons/Yr	based on a 12-month rolling sum PM10
C04	DUST COLLECTOR, DRY BUILDING A/B
Emission Limit	
4.000 Tons/Yr	12-month rolling PM10
C205	DUST COLLECTOR, DRY BUILDING HENSCHEL
Emission Limit	
2.300 Tons/Yr	12-month rolling sum PM10
C211	DUST COLLECTOR, WET BUILDING, D-WING #2
Emission Limit	
1.000 Tons/Yr	based on a 12-month rolling sum PM10

**SECTION G. Emission Restriction Summary.****Site Emission Restriction Summary**

Emission Limit		Pollutant
9.900 Tons/Yr	each single HAP, 12-month rolling sum	Hazardous Air Pollutants
24.900 Tons/Yr	12-month rolling sum	VOC
24.900 Tons/Yr	combined HAPs, 12-month rolling sum	Hazardous Air Pollutants
24.900 Tons/Yr	12-month rolling sum	NOX
99.900 Tons/Yr	12-month rolling sum	PM10

Alternative Operation Emission Restriction Summary

Source Id	Source Description
-----------	--------------------

**SECTION H. Miscellaneous.**

September 2012: Original Issuance (APS 738006, AUTH 861333)

The following previously issued approvals serves as a basis for certain conditions in this operating permit:

Plan Approval No. 46-0262A Source Ids: 205, 206, 207, 208, 209, 210, 211, and 212

Plan Approval No. 46-313-146 Source Ids: 101, 102, 103, 105, 106, 107, 108, 109, 110, 111, 112, 113, 114, 115, 116, 117, 118, 119, and 120

Plan Approval No. 46-0262B Source Ids: 121, 122, C205

Plan Approval No. 46-0262C Source Ids: 123, C209, C03

Plan Approval No. 46-0262D Source Ids: 109, C04

Plan Approval No. 46-0262F Source Ids: 213, C213

The Department has determined that the emissions from the following activities, excluding those indicated as site level requirements, in Section C, of this permit, do not require additional limitations, monitoring, or recordkeeping:

RFD No: 1063 Replacement of two media mills in building #2 (50 liters, 135-B was replaced with 50 liters, VMMC14; and 15 liters, 132 was replaced with 17 liters, VMMC15) under Source Id: 101.

RFD No. 3448 – January 2013 – Installation of an air stripper

RFD No. 3534 – March 2013 – Installation of a media mill for PMDD4

RFD No. 3576 – April 2013 – Installation of a media mill for PMDD3

RFD No. 3821 – July 2013 – Increase production on PMDD3

RFD No. 3874 – July 2013 – Installation of circulation tanks

RFD No. 4952 – February 2015 – Installation of Extruder E11

RFD No. 5222 – July 2015 – Installation of a high speed mixer

RFD No. 5235 – July 2015 – Installation of high speed mixer (replaces RFD No. 5222)

RFD No. 5246 – July 2015 – Replacement of a media mill

RFD No. 5291 – September 2015 – Operate RTO at lower temperatures during stack test

RFD No. 5543 – January 2016 – Installation of a media mill

RFD No. 5609 – March 2016 – Installation of a new high speed mixer

RFD No. 5665 – April 2016 – Replacement of a roll mill

RFD No. 5950 – September 2016 – Installation of an extruder and relocation of an existing extruder

RFD No. 6895 - March 2018 - Installation of a media mill operating as part of Source ID 211 (PMDD3), which is included in Source ID 200

AUTO-EXEMPT - December 2018 - Replacement of Laboratory Paint Spray Booth

RFD No. 7610 - March 2019 - Reconfiguration of Extruders (E4, E6, E8, and E15) venting to Dust Collector C115 (decommissioned) and C04

RFD No. 7892 - July 2019 - Wet Building (Source ID 200) - Replace the current RMG2 (50" mill; Source 108) with an old 60" mill that has been kept in storage; Replace the current RMF1 (60" mill; Source 106) with the current RMG2 (50" mill; Source 108); Replace the current RMG1 (60" mill; Source 108) with the current RMF1 (60" mill; Source 106); Replace the current RMH4 (42" mill; Source 108) with the current RMG1 (60" mill; Source 108)

RFD No. 8458 - May 2020 - Dry Building (Source ID 100) - Removal of Extruder E13 and F2; Installation of Extruder E16; Relocation of Extruders E2 and E12 but no change in controls (C205)

RFD No. 9182 - June 2021 - Dry Building (Source ID 100) - Removal of Extruder E2 and Controls C116 and C117; Installation of Extruder E17, E18, and E19 (each with its own mixer); Reconfigure various units (C205) refer to MMOP 09/2021

RFD No. 9591 - February 2022 - Replacement of Pre-Mixer B100 with Pre-Mixer Henschel 10 (H10)

RFD No. 10498 - January 2024 - Installation of two pre-mix dispersion units and new dust collector

RFD No. 10649 - April 2024 - Replacement of Media Mill VMMC16 in C Wing with a new Media Mill HMMC20, and installation of Basket Mill BME1 in Wing E

RFD No. 10669 - May 2024 - Replace equipment in the Dry Building 1; Replacement of Henschel H6 High Intensity Mixer (Premix Room) 1000 liter and Henschel H7 High Intensity Mixer (Premix Room) 1500 liter with the new (smaller) High Intensity Mixers H11 (1200 liters) and H12 (600 liters)

RFD No. 11248 - Replace equipment in the C Wing of Wet Building 2; Replacement of Horizontal Media Mill (HMMC2) with a new Cowles Mixer and Netzsch Neos Mill (NEOS20) and the replacement of Horizontal Media Mill (HMMC7) with a new Cowles Mixer and Buhler Invicta 3 Mill (MMI3)

Insignificant Boilers and heaters:

Natural gas fired Burnham Boiler rated at 8.36 MMBtu/hr (2-VES-005)

Natural gas fired Fulton Boiler rated at 1.6 MMBtu/hr (1-VES-003)

(2) Rapid Air units each rated at 3.575 MMBtu/hr (2-RAU-001)

**SECTION H. Miscellaneous.**

Gas Heater rated at 0.3 MMBtu/hr
 (2) Oil Space Heaters each rated at 0.3 MMBtu/hr *REMOVED*
 Fulton Boiler EDR-2000 (1-VES-012) rated at 2.0 MMBtu/hr
 Fulton Boiler EDR+2500 (2-VES-027) rated at 2.5 MMBtu/hr
 15 Roof Top Units (RTU) on Building 1, total capacity = 1.74 MMBtu/hr
 2 Hot Water Heaters in Building 1, total capacity = 0.398 MMBtu/hr
 4 Hot Water Heaters in Building 2, total capacity = 1.196 MMBtu/hr
 2 Hot Water Heaters in the GTC Pump Room, total capacity = 3.0 MMBtu/hr
 9 Space Heaters in Building 1, total capacity = 22.343 MMBtu/hr
 3 Space Heaters in the Maintenance Shop, total capacity = 1.2 MMBtu/hr

Storage Tanks:

Seven 10,000 gal; One 7,500 gal; Four 6,000 gal; One 5,000 gal; One 3,384 gal; Three 3,000 gal; Two 2,000 gal; and number of 7,500 gal storage tanks called Tank Farm with non-VOC, non-HAP content.

Source of particulate matter controlled by dust collectors that are vented indoors:
 Post Blender RB2, Blender RB3 and Blender A-1 controlled by 2,000 cfm Dry Ribbon Blender Dust Collector
 Post Blender T15 controlled by Dry T15 Dust Collector
 Resin Transfer System with Filters
 Ribbon Bender RB1 with Cyclone
 Dry Vertical Blender with Cyclone
 Drum loading (across from roll mill G) with small dust collector
 Two set-up areas with small dust collectors

Other Trivial Activities:

Classifiers (8 Swecos)
 Air Compressors and Pneumatically Operated Equipment
 Central Vacuum System
 Chippers H1 through H4 and associated dust collector
 Resin Silos
 Three Heated Sand Baths (Burn-off ovens)
 Waste Collection Containers and Storage Areas
 Empty Drums
 Pot Storage
 Quality Control and R&D Laboratories
 Hot Water Heaters
 Solvent Storage Room
 B2 Pulverizer
 #2 Fuel oil tanks for the Generators
 Cone tumbler (located in the E/F line area)
 Premix room cone tumbler (located in the E/F line area)
 Pulverizers E and B
 Chipper B1
 Chipper B2
 Bag loader (located near vertical blender)
 Dry Cowles Dissolver that vents indoors without control

June 2013: Administrative Amendment (APS No. 738006, AUTH ID 980396) - This administrative amendment addresses the following items:

- (1) Incorporates terms and conditions of Plan Approval No. 46-0262C, which is for the installation of a pre-mix dispersion machine (Source ID 123 - Pre Mix Dispenser PMDD4), controlled by existing C209 (D-Wing Dust Collector) and C03 (Regenerative Thermal Oxidizer).
- (2) Revises the monitoring and recordkeeping system from using predetermined emission factors per equipment to the more reliable method using mass balance, tracking raw material used, and final product produced, calculating losses as PM and VOC



SECTION H. Miscellaneous.

emissions.

(3) Revises various general items for clarification, consistency, and/or correction of minor errors in Section C (Site Level) and Section D (Source Level). There are no physical impacts on source operations and no changes to state or federal regulations with these minor corrections throughout the permit.

October 2013: Minor Operating Permit Modification (APS No. 738006, AUTH ID 991780) - This minor modification address the increase of production from 1,250 tons to 2,500 tons for a pre mix disperser unit, Source Id 211.

January 2014: Administrative Amendment (APS No. 738006, AUTH ID 1009515) - This administrative amendment incorporates terms and conditions from Plan Approval No. 46-0262B, which allows for the installation of two (2) extruder machines - Source ID 121 (Dry Building Extruder E12) and Source ID 122 (Dry Building Extruder E13), which exhaust to the existing dust collector (C205 - Dust Collector, Dry Building Henschel).

February 2015: Administrative Amendment (APS 738006, AUTH ID 1061308) - This administrative amendment incorporates terms and conditions applicable to Extruder E11 from Plan Approval No. 46-0262D. The additional extruder operates as part of Source ID 109 in the Dry Building, which exhausts to the existing dust collector (C04 - Dust Collector, Dry Building A/B).

September 2017: Renewal Permit (APS 738006; AUTH ID 1170333) - The following items are addressed with the renewal permit:

(a) Material Safety Data Sheets (MSDS) have been replaced by SDS (Safety Data Sheets). The permit has been revised to reflect this change in Hazardous Communication Standards under OSHA directive.

(2) Source ID 032 (Dual Fired Boilers) and Source ID 033 (Fuel Oil Boilers) have been created in order to add the applicable requirements of 40 CFR Part 63 Subpart JJJJJJ to each fuel oil boiler. The natural gas fired boilers remain listed in Section H of the permit and are exempt from the requirements of 40 CFR Part 63 Subpart JJJJJJ.

(3) Source ID 100 and 200 - Individual units have been removed from the permit and two (2) "umbrella" source IDs have been created in order to group multiple units with similar permit conditions.

(4) All control devices are now listed individually in Section D with specific permit conditions listed under each dust collector or the Regenerative Thermal Oxidizer (RTO), as applicable.

(5) 24-hour averaging period has been added to each VOC pound per hour emission limit, as applicable.

(6) Source ID 126 – Emergency Generator - two (2) exempt emergency generators, each powered by a stationary internal combustion engine; applicable state and federal regulations have been added to the permit.

(7) Source ID 204 – Degreasers - There are 15 degreasing units located throughout the plant in the Wet Building. Most of the units are cold cleaning immersion machines; there is one (1) remote reservoir unit in the Maintenance Area. The applicable requirements of 25 Pa. Code § 129.63 have been corrected in the permit.

(8) Control Device C03 – Regenerative Thermal Oxidizer - Maintaining the thermal oxidizer at lower operating temperatures based on test data has been added to the permit.

(9) Insignificant activities have been added to the RFD summary above in this Section H of the permit.



SECTION H. Miscellaneous.

(10) The facility is currently on a weekly frequency for perimeter monitoring of visible emissions, odors, and fugitive emissions. * See updated information September 2021 * Current frequency is Monthly *

April 2019: Minor Modification (AUTH ID 1266864; APS No. 738006) - Dust Collector C115 (Control Device ID C115) has been decommissioned and removed from the permit. Extruder E4, E6,E8, and Extruder E15 have been rerouted to Dust Collector C04 (Control Device C04). Refer to RFD No. 7610 (also added to Section H above).

September 2021: Minor Modification (AUTH ID 1366980; APS No. 738006) - Dry Building modifications and projects (refer to RFD No. 9182):

- (1) Removal of Extruder E2 and addition of Extruder E17 to exhaust to Dust Collector C205
- (2) Removal of Dust Collector C117 and relocate Extruders CM1, CM2, and F4 from Dust Collector C117 to Dust Collector C205
- (3) Removal of Dust Collector C116 and relocation of E Roll Mill, Henschel H1, Henschel H2, Henschel H5, Pulverizers from Dust Collector C116 to Dust Collector C205
- (4) Reconfigure Blender F from Dust Collector C116 to Dust Collector C110
- (5) Addition of new Extruders E18 and E19, Mixers M1 and M2, and Loading Lines L1 and L2, to be controlled by existing Dust Collector C04
- (6) Relocate post-blend tote loading/unloading activities from Source ID 109 venting to Control Device C04 to exhaust to an internally vented dust collector
- (7) Remove laboratory equipment of Source ID 115 which formerly vented to Dust Collector C04
- (8) RFD No. 7892, RFD No. 8458, and RFD No. 9182 have been added to the RFD list above in this section of the permit
- (9) The permit contact has been updated to Mr. Jeff Zaskoda; the responsible official has been updated to Mr. William Scilingo
- (10) The facility is currently on a monthly frequency for perimeter monitoring of visible emissions, odors, and fugitive emissions (letter dated May 1, 2018).

December 2022: Renewal Permit (AUTH ID 1384135) - The following items are addressed with this renewal permit:

- (1) Facility-wide PM emission limit has been added to the synthetic minor restriction condition, and fuel usage limits have been added to Section C in order for the NOx synthetic minor PTE limit to be practical and enforceable.
- (2) Source ID 100 has been renamed Dry Building 1 – Plastic Masterbatch Center.
- (3) Source ID 200 has been renamed Wet Building 2 – Liquid Dispersion Center.
- (4) Small natural gas boilers and heaters have been added to this section, above. AIMS Source ID 031 is available for reporting purposes for all of the exempt natural-gas consuming sources on an aggregate basis.
- (5) The 5.021 MMBtu/hr York Shipley Boiler located in the hot water boiler room has been removed from the facility and is no longer listed under Source ID 033. Source ID 033 now contains only two (2) No. 2 fuel oil boilers.
- (6) The total number of parts washers is now 10. One (1) remote reservoir machine is located in the maintenance area (Source ID 204). Nine (9) immersion machines are located in Building and are now listed as Source ID 214 in order to incorporate an equivalency method of compliance in accordance with 25 Pa. Code § 129.51.
- (7) RFD No. 9591 for the replacement of Pre-Mixer B100 with Pre-Mixer Henschel 10 (H10) has been added to this section of the permit.
- (8) Evaluating each of the seven (7) permanent total enclosures separately has been added to the testing condition under the RTO (C03).



SECTION H. Miscellaneous.

February 2024: Administrative Amendment (AUTH ID 1468576) to incorporate terms and conditions of Plan Approval No. 46-0262F which is for the installation of the C6 continuous process line (213) and a new baghouse (C213) operating in the Dry Building 1 – Plastic Masterbatch Center (Source ID 100). Additionally, the following existing equipment is rerouted to the new dust collector: weigh set-up and resin loading.

April 2024: Minor Modification (AUTH ID 1479941; APS No. 738006) - Wet Building modification and projects (refer to RFD No. 10649):

- (1) Replace Media Mill VMCM16 in C Wing with new Media Mill HMMC20.
- (2) Install new Basket Mill BME1 in Wing E, and remove Steel Ball Mill (SBME2).

June 2024: Minor Modification (AUTH ID 1485791) - Replace Henschel High Intensity Mixers in Dry Building (refer to RFD No. 10669):

- (1) Replace Henschel H6 High Intensity Mixer (1000 liter) with a new Henschel H11 High Intensity Mixer (1200 liter)
- (2) Replace Henschel H7 High Intensity Mixer (1500 liter) with a new Henschel H12 High Intensity Mixer (600 liter).

November 2024: Administrative Amendment (AUTH ID 1506804) - Update Responsible Official from William Scilingo to Jeffrey Zaskoda.

October 2025: Minor Modification (AUTH ID 1541205) - Replace equipment in the C Wing of the Wet Building (refer to RFD No. 11248):

- (1) Replace Horizontal Media Mill (HMMC2) with a new Cowles Mixer and Netzsch Neos Mill (NEOS20)
- (2) Replace Horizontal Media Mill (HMMC7) with the new Cowles Mixer and Buhler Invicta 3 Mill (MMI3).

January 2026: Administrative Amendment (AUTH ID 1553092) to incorporate terms and conditions of Plan Approval No. 46-0262G which allows for the alternate concentration-based VOC emission limit for the RTO (Control Device C03).

March 2026: Minor Modification (AUTH ID 1558214) to remove individual equipment throughput restrictions and monitoring and recordkeeping. Source Level requirements apply per building, i.e. Source ID 100 and Source ID 200.



***** End of Report *****
